

**CENTRE FOR
COMPUTING AND BIOMETRICS**

**A plant root-morphology based
simulation for plant/soil microbial
ecosystem modelling**

T.N. Brown, D. Kulasiri and R.E. Gaunt

Research Report No:96/08
September 1996

RESEARCH
REPORT

ISSN 1173-8405

LINCOLN
UNIVERSITY
Te Whare Wānaka O Aoraki

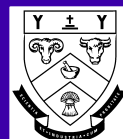

Centre for Computing and Biometrics

The Centre for Computing and Biometrics (CCB) has both an academic (teaching and research) role and a computer services role. The academic section teaches subjects leading to a Bachelor of Applied Computing degree and a computing major in the BCM degree. In addition it contributes computing, statistics and mathematics subjects to a wide range of other Lincoln University degrees. The CCB is also strongly involved in postgraduate teaching leading to honours, masters and PhD degrees. The department has active research interests in modelling and simulation, applied statistics and statistical consulting, end user computing, computer assisted learning, networking, geometric modelling, visualisation, databases and information sharing.

The Computer Services section provides and supports the computer facilities used throughout Lincoln University for teaching, research and administration. It is also responsible for the telecommunications services of the University.

Research Report Editors

Every paper appearing in this series has undergone editorial review within the Centre for Computing and Biometrics. Current members of the editorial panel are

Dr Alan McKinnon	Dr Keith Unsworth
Dr Bill Rosenberg	Dr Don Kulasiri
Dr Clare Churcher	Mr Kenneth Choo
Dr Jim Young	

The views expressed in this paper are not necessarily the same as those held by members of the editorial panel. The accuracy of the information presented in this paper is the sole responsibility of the authors.

Copyright

Copyright remains with the authors. Unless otherwise stated, permission to copy for research or teaching purposes is granted on the condition that the authors and the series are given due acknowledgement. Reproduction in any form for purposes other than research or teaching is forbidden unless prior written permission has been obtained from the authors.

Correspondence

This paper represents work to date and may not necessarily form the basis for the authors' final conclusions relating to this topic. It is likely, however, that the paper will appear in some form in a journal or in conference proceedings in the near future. The authors would be pleased to receive correspondence in connection with any of the issues raised in this paper. Please contact the authors either by email or by writing to the address below.

Any correspondence concerning the series should be sent to:

The Editor
Centre for Computing and Biometrics
PO Box 84
Lincoln University
Canterbury, NEW ZEALAND
Email: computing@lincoln.ac.nz

A plant root-morphology based simulation for plant soil microbial ecosystem modelling.

T.N. BROWN^a D. KULASIRI^a R.E. GAUNT^b

^a Centre for Computing and Biometrics, Lincoln University, New Zealand

^b Plant Science Department, Lincoln University, New Zealand

A simulation model to produce and manipulate computer representations of plant root microbial ecosystems is presented. The root system is described as a collection of nodes. A node records a position in three-dimensional space and may represent the origin of another root, a bend, or some change in the root's microbial status. Disease lesions, closely associated microbial populations such as mycorrhizal fungi, and free soil microbial populations may be represented. A multi-dimensional matrix structure provides a useful conceptual framework for the numerous stochastic functions required by the model. Procedures for building the node based root map, and for simulating root growth and microbial interaction, are presented in terms of such a matrix, in conjunction with the necessary manipulations of the node lists which represent the root system. The model is presented as a step towards a generic framework for modelling root-architecture and the spatial structure of associated microbial ecosystems. The model has been successfully applied to a simulation of a *Pinus radiata* / *Armillaria spp.* pathosystem.

Key words: Three-dimensional tree root architecture. Spatial microbial ecosystem simulation model.

1 Introduction

The plant root / soil microbial ecosystem has all the complexity and variability normally found in multi-species ecosystems. Its existence within the soil matrix introduces further complications. Monitoring and experimental modification are difficult, so simulation and modelling are useful additions to purely experimental research. The constraining effect of the soil, and the unusual topology of the root surface environment, compared to terrestrial or aquatic environments, require special consideration during model formulation. A generic model capable of simulating root morphology and the positions and spatial interactions of microbial populations and nutrients would have

many applications. For example, Lungley [13] tracked branching patterns in cereal root systems to examine fertiliser uptake efficiency. Bloomberg [2,3] and Reynolds [15] used root system morphology simulations specifically tailored to conifer nursery conditions to model disease spread in Douglas fir nursery beds. Schlichter *et al.* [17] looked at root system shape and its effect on rain infiltration. Fitter *et al.* [10] considered the effect of branching patterns on soil volume exploitation. Schlichter *et al.* used simple geometric shapes (combinations of cones and cylinders) to represent the root volume, but in all the other cases essentially the same root morphology simulation problem had to be addressed. The goal of this work is to move towards a generalised root architecture and microbial ecosystem modelling framework.

Various approaches have been considered for root architecture modelling. Diggle [9] treated root tips as moving particles, and tracked their paths to produce three dimensional structures. This approach is perhaps ideally suited to the fine root systems of annual crops, for example, Lungley's work. Henderson *et al.* [12,11] used collections of inter-connected points in three dimensional space to represent the morphology of Sitka Spruce root systems accurately. Stochastic functions for features such as branching frequency and direction and root length were derived from observations of root systems excavated in the field. The model was used to test hypotheses concerning controlled patterns in root system development concealed by the overall variability imposed by the heterogeneity of the soil matrix.

The approach of Henderson *et al.* [12,11] has been used as a basis for the root architecture component of our simulation model. Algorithms describing the three-dimensional growth of the root system, and methods for representing microbial species and other features of the root soil environment, have been developed. The model has been applied to the *Pinus radiata* / *Armillaria spp.* pathosystem [5,4], and is presented here in its generic form.

2 Formulation

For the purposes of this simulation model, root systems are considered as branching structures originating from a 0th order root (the root collar at the base of the stem). A branch from an n 'th order root gives rise to an n 'th+1 order root, these roots being referred to as "parent" and "child" roots respectively.

2.1 Nodes

The basic element in the model's representation of a root system is the node. The term is used to describe a point in space, and a corresponding entry in a list, it does not refer to a node in the normal botanical sense. A node has a position, an x, y, z coordinate, in three-dimensional space. There may be many different types of node, and each type possesses the information required to describe the feature the node represents. Nodes are manipulated as lists, or sequences, in the order they occur along a root (proximal to distal, stem to tip). As all changes in a root system's state are represented by nodes, it follows that the lines between nodes, the internodes, represent homogeneous sections of root. Figure 1 illustrates the translation from a real root system to the node based representation. It is convenient to define the term "root position" to refer to the one-dimensional local coordinate system identifying a node's position on a root. This may be normalised (0..1), or in the range 0.. l , where l is the length of the root. The proximal end of the root is taken as the root position origin. All nodes possess, in addition to their x, y, z coordinate, a root position coordinate, with the node representing the end of the root occurring at the local coordinate l .

The simplest type of node, the "Bend" node (Figure 1), records a three-dimensional coordinate through which the root passes. The "End" node represents the root tip, and is also simply a three-dimensional coordinate. A "Branch" node marks the origin of a "child" root, a root of the next order. As well as a three-dimensional coordinate, a Branch node records details such as the physiological stage of the child root, and possibly the time at which it will advance to the next physiological stage. If required, other overall characteristics of the child root may also be specified by the Branch node on the parent root.

Forking, the division of a root of order n into two roots of order $n + 1$, may be represented in two ways, the most appropriate being dictated by the system being modelled. The simpler case (Figure 2 (a)) is not strictly a fork but a branching and deflection of the n 'th order root, with only one $n + 1$ order root appearing. Alternatively the n 'th order root may have two Branch nodes immediately preceding its End node, all three nodes sharing the same position, and so more accurately representing a true fork (Figure 2 (b)).

Fungal¹ nodes are used to indicate an increase or decrease in the "density" of a fungal population on a root's surface. As well as the position information common to all nodes a Fungal node will possess a code identifying the fungus

¹ While this model has been described with reference to fungal colonisation of roots, it may be possible to treat some rhizosphere bacterial populations in an analogous manner.

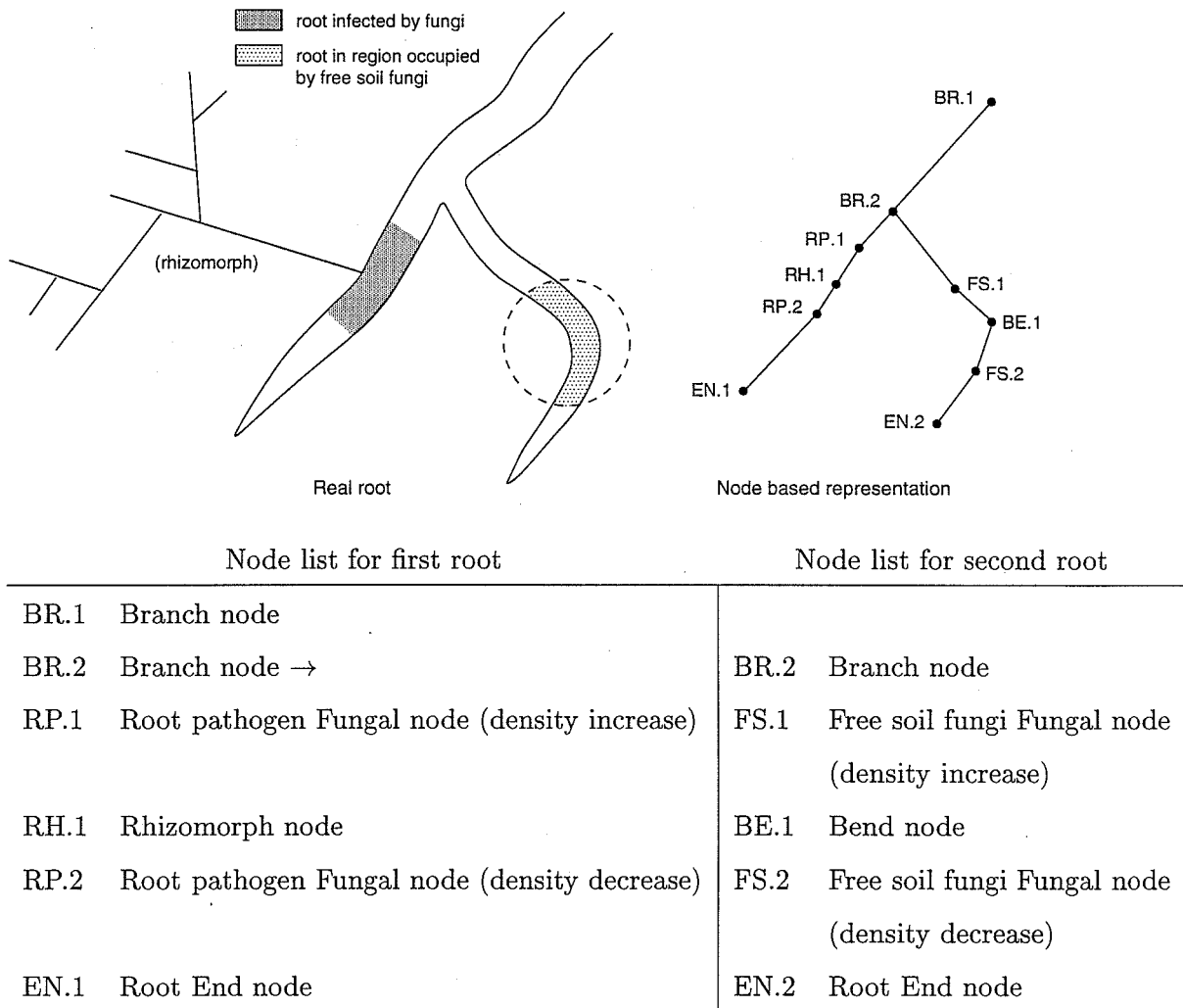

Fig. 1. Translation from a real root to the node based representation.

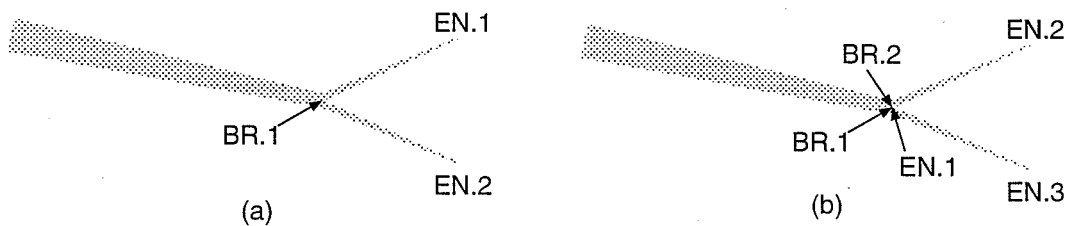

Fig. 2. Alternative node based representations of fork type branching.

it represents. Fungal nodes may represent pathogenic, symbiotic, beneficial or merely commensal fungi. Density may be defined to suit the system being modelled, examples include mm of hyphae per mm² of root surface, colony forming units per mm of root, infection severity (degree of tissue colonisation), and moles of a fungal metabolite per gram of root material. An area of fungal infection or colonisation can be represented by a pair of Fungal nodes, with the proximal node denoting a step-wise increase from a zero density, and the distal node marking a corresponding drop to zero density. Additional Fungal

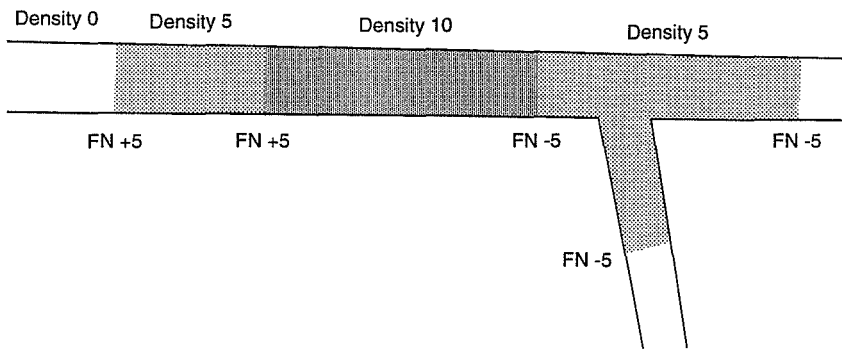

Fig. 3. Fungal nodes representing colonised areas with variable density and spread onto a child root.

nodes may be used to represent a graduated increase in density towards the centre of a colonised area (Figure 3). Alternatively a continuously varying density function may be used to determine fungal density between fungal nodes. When a colonised area extends either side of a Branch node, a Fungal node will be required on the child root to delimit the colonised area, as a child root initially has the fungal density of its parent root at the Branch node the child originates from (Figure 3).

Other root system features, such as rhizomorphs, mycorrhizal feeder hyphae, and tubers, may be represented by other types of node which incorporate appropriate information. Rhizomorphs (root like fungal growths) can in turn be represented by the node based model described here. The branching of a fungal mycelium could also be modelled, but only at a restricted scale (a soil volume less than 0.001 m^3) as the data required to define the complex branching and bending of mycelium in soil is considerable.

Root diameter may be handled in a manner that reflects its importance in the system under study. A diameter could be specified for the beginning of each root, and a tapering function used to model the specific diameter at any point along the root. If greater flexibility were required, a diameter could be specified at each node, and a tapering function used only between one node and the next.

Free soil fungi, not as closely associated with the root as pathogenic or mycorrhizal species, can also be included in the modelled system, either as a collection of spherical volumes, or as "colonised" areas delimited by Fungal nodes, as described previously. In the latter case the nodes delimiting the "colonised" area are initially positioned by the intersection of the root system with spherical volumes. Retaining this Fungal node representation avoids the necessity of constantly checking a section of root for intersection with a collection of spherical volumes.

Features	Attributes						
	Length	Elongation	Number	Position	Angle	Azimuth	Lifespan
Root	○	○			○	○	○
Branch			○	○	○	○	
Bend			○	○	○	○	
Fungi	○	○	○	○	○	○	○

Table 1
Root variable matrix form.

2.2 Stochastic function matrix

A large number of variables are required to describe the geometry and development of a root system [12]. For each order of root to be modelled, the number and position of bends, branches, and initial fungal colonisations must be known. Changes in a root's direction at these points, and the initial direction of growth of its child roots, must also be predicted. Many of the stochastic functions used for these parameters will change for each physiological stage of the root system. Finally, if more than one type (species) of root system is to be simulated, completely different sets of parameters are required. Figure 4 illustrates the complexity of a *Pinus radiata* root system mapped in the field, and the ability of the method described to represent that complexity.

To ease handling of the cumbersome array of functions required, notation of the form

$$F_{type,order,feature,attribute,phys.stage,funus}$$

is used. Table 1 lists some root features and the attributes they can possess. Table 2 gives some examples of elements of the resulting stochastic function matrix and their interpretation. Angle and azimuth refer to a root's "compass" direction and declination from the horizontal, respectively.

Notation	Meaning
$F_{Pine,2,Root,Length,NA,NA}$	Length of a second order pine root, physiological stage is irrelevant as length is defined when the root is first created. Fungus is also probably irrelevant. Possible value: <i>Uniform</i> (50, 200) mm.
$F_{Pine,2,Fungi,Elong.,Mature,Arm.}$	Rate of elongation of an armillaria lesion on a Mature second order pine root. Possible value: $1.5 \times S()$ mm day ⁻¹ , where $S()$ represents a seasonal / climatic effect.
$F_{Rye,1,Branch,Number,NA,NA}$	Number of branches on a first order root of a rye grass. Possible value: <i>Uniform</i> (0, 6).
$F_{Pine,3,Branch,Angle,NA,NA}$	Change in direction of a third order pine root at a Branch Node. Possible value: 0 radians (no change).
$F_{Pine,2,Root,Lifespan,Senescent,NA}$	Duration of senescent physiological phase for a second order Pine root. Possible value: <i>Exp</i> (20) (exponential mean= 20) days.

Table 2

Examples of root-variable matrix elements. *NA* = not applicable.

2.3 Simulated root system construction

The type of plant, and its position, will be defined by the simulation user. For example, a root system may be constructed from the initial information that a plant of type *Pine* has its root collar, or 0th order root, at x_0, y_0, z_0 . The direction of the 0th order root will normally be straight down ($angle = -\pi/2$, $azimuth$ undefined), but any direction is valid. Given this information, the following node-list building procedure is used to pre-define a root system's geometry. *NA* = not applicable.

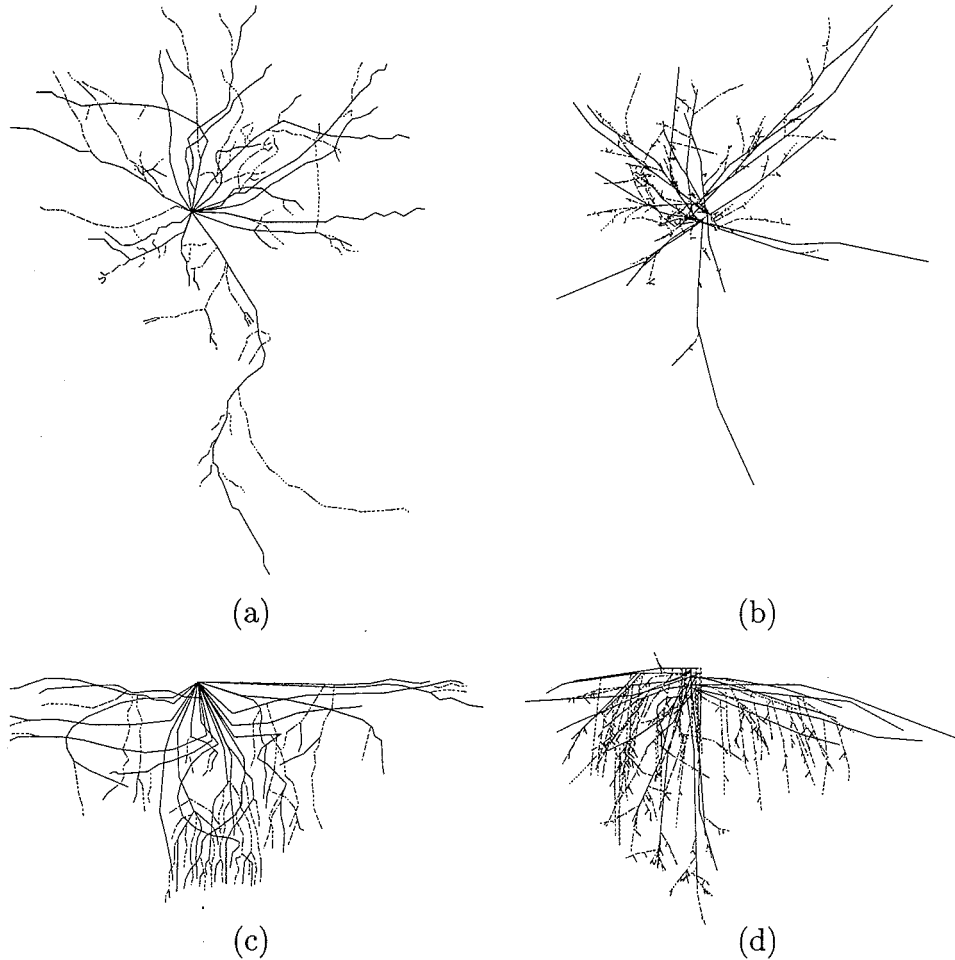

Fig. 4. Comparison between real (a and c) and simulated (b and d) root systems in plan (a and b) and elevation (c and d). a and c are digitised forms of root maps made available by Alex Watson [20].

- (i) To the empty node list, add an End node with a root position value of $F_{type,order,Root,Length,NA,NA}$. Note that the three-dimensional position of the nodes is undefined at this stage, only the one-dimensional root position is calculated.
- (ii) Add $F_{type,order,Bend,Number,NA,NA}$ Bend nodes, with root position values of $F_{type,order,Bend,Position,NA,NA}$.
- (iii) Add $F_{type,order,Branch,Number,NA,NA}$ Branch nodes, with root position values of $F_{type,order,Branch,Position,NA,NA}$.
- (iv) For each fungal species, add $F_{type,order,Fungi,Number,NA,Species}$ density incrementing Fungal nodes, with root position values of $F_{type,order,Fungi,Position,NA,Species}$, and corresponding density decrementing Fungal nodes $F_{type,order,Fungi,Length,NA,Species}$ root position units further down the root.
- (v) Starting from the known initial x, y, z location and angle and azimuth, calculate the location of the first node. Modify the root's angle and azimuth by $F_{type,order,ntype,Angle,NA,NA}$ and $F_{type,order,ntype,Azimuth,NA,NA}$, where

ntype is the type of this node. Repeat this step to calculate the locations of the remaining nodes.

- (vi) For each Branch node repeat this procedure to add a root of the next order.
- (vii) For each child root originating from a Branch node occurring in a colonised section of root, add a Fungal density decrement node to mark the limit of the colonised area on the child root.

2.4 *Root growth*

The temporal development of the root system can be simulated either by modelling the behaviour of the root tip, or by modelling the geometric structure of the mature root system. In the former case the position of the root End node would be updated, and Bend, Branch and other nodes added as required. In the latter case the final three-dimensional geometry of the root system is modelled at the beginning of the simulation; a Current End node is used in addition to the true End node to record the extent to which the root system has grown. Although the shape of the system is defined beyond the Current End, the Current End node represents the root tip. Growth is modelled by having the Current End node move along the internodes of the predefined root system. The latter technique has been used to date, as a single parameterisation can be used to model the complete spatial / temporal development of the root system. The root tip approach may require a variety of different submodels of root tip behaviour at different stages of the root system's development, and for different classes of root. The use of a pre-defined morphology does not prevent simulation of the effect of the root system's development on the overall structure. The Current End node will not necessarily reach the Root End node, and branching and growth rates will all affect the final morphology of the root system.

2.5 *Physiological status*

While the model described here aims primarily to represent the spatial structure of the root ecosystem, root / fungi interactions are also dependent on the physiological status of both plant and fungus. The physiological stage of the whole root may be recorded by its first node (the Branch node), or if more precision is required, by each node. A physiological stage can be considered to be part of a progression of stages. Table 3 lists the stages used in an application of the model to the *Pinus radiata* / *Armillaria spp.* pathosystem.

Phase	Description
Future	A root that doesn't exist yet, i.e. one occurring past the Current End node of its parent.
Waiting	The Current End node of the parent has passed this position, but the root is not yet growing. For example, to allow additional first order roots to appear on the root collar several seasons after the plant starts to grow.
Growing	Actively elongating, child roots that die will be replaced by a localised application of the root construction procedure described below.
Mature	Similar to Growing, but with slower replacement of child roots.
Senescent	Retains some resistance to fungal attack, but is not elongating, and has no active child roots (i.e. all child roots will also be Senescent or older).
Dead	Reduced resistance to fungal attack, negative elongation may represent decay of distal end. Prime source of fungal inocula.
Decayed	In an advanced state of decay, may favour specialist saprophytes over pathogenic species.

Table 3
Root physiological phases.

2.6 Analysis

As each internode of each root is examined during the course of a simulation, it is necessary to know what type of plant the internode belongs to, the root's fungal load, the state of the root system nearby, the internode's direction of

travel, etc. All this information could be stored in each node record, but that would be extremely inefficient, as the information is merely a function of other values already stored. Instead, a “status record” is used. The status record is essentially a collection of information about the root system at a specific place and time. The status record may include the following values, only some of which will be relevant to any given analysis.

Status record

x, y, z	The coordinates of the place in the root system to which the status record applies.
<i>order</i>	the order of the root to which the status record applies.
<i>angle</i>	the angle of the internode
<i>azimuth</i>	the azimuth of the internode
<i>stage</i>	The physiological stage of the root to which the status record applies.
$fungi_{mod}$	Modification factor for plant/fungal and fungal/fungal interactions from seasonal and environmental effects.
$fungi_1$	The density of fungal populations at the point to which the status record applies.
$fungi_2$	The mass (length \times density) of any fungal populations that the point to which the status record applies lies within.
$fungi_3$	The mass of any fungal populations between the point to which the status record applies and the stem.

The last three components are illustrated in Figure 5. At the node P , $fungi_1$ is d_1 , $fungi_2$ is $d_1(l_4 + l_5) + d_2 \times l_3$ and $fungi_3$ is $d_1(l_1 + l_4) + d_2(l_2 + l_3)$. The advantage of the status record is that only one is required, it “belongs” to the analysis, rather than to the root system.

In many cases it is useful to isolate a subset of roots or internodes (root sections) based on some arbitrary criteria. The simplest case arises when roots of only one order are of interest. More complicated conditions may also be useful, for example it may be necessary to isolate root-rot infected sub-sections of mature second order roots without significant biological control agent populations to estimate the number of possible sporulation sites. Most of these root system states can be described by defining a minimum and maximum status record. Only those internodes whose own status records lie between the minimum and maximum are selected.

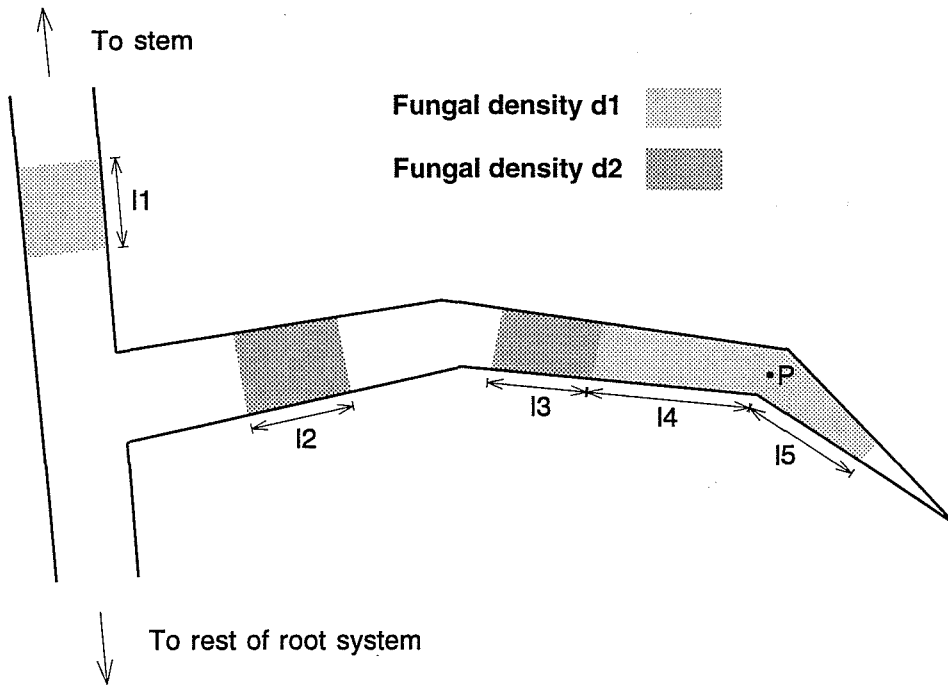

Fig. 5. Fungal status information stored in a "status record".

2.7 Parsing

To simplify the examination and alteration of the set of records that represent the root system, any implementation will almost certainly include a "parser" entity. The parser will be able to process the lists of nodes and present the "client" routine (for example, an analysis routine determining the proportion of the root system infected) with the start-node and end-nodes and status records for each internode. Figure 6 illustrates the lists of pairs of nodes a parser routine would pass to its client routine for a simple two root system, where root B branches from root A.

For root A, the parser would give the client routine the node pairs BR.1-BE.1, BE.1-BR.2, BR.2-BE.2, and BE.2-EN.1. For root B, BR.2-FN.1, FN.1-FN.2, and FN.2-EN.2. Depending on the implementation, the client routine could receive the root B data in the middle of the root A data, between BE.1-BR.2 and BR.2-BE.2, or after root A had been fully processed. If, for example, the client routine was determining the proportion of the root system that was colonised by a fungus, it would find the total length of the root system by summing all the internode lengths, and the length of infected root by summing the lengths of internodes whose status record had a non-zero density for the fungus in question (the internode FN.1-FN.2 in this example). If the client routine was concerned only with colonisation above a certain density, a pair of minimum / maximum status records could be supplied to act as a filter.

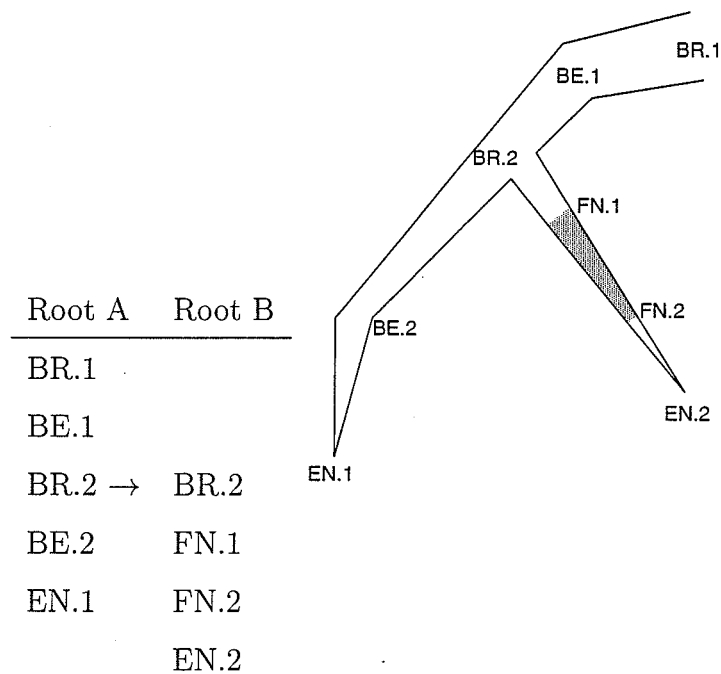

Fig. 6. Node pairs defining internodes.

2.8 Fungal growth

The expansion (or contraction), of fungal lesions (or areas colonised by harmless or beneficial species) can be represented by “sliding” the fungal nodes up and down the root. A lesion expands when its proximal node moves “up” the root towards the stem, and/or its distal end moves “down” the root towards the root tip. As these mobile nodes encounter other nodes, further modifications to the root system may be required. Figure 7 illustrates the possible node interactions:

- Fungal node 3 passes bend node 2. The nodes swap their positions on the list of nodes for the root (3 now occurs before 2), but no other change occurs.
- Fungal node 2 reaches branch node 1. Assuming the fungus spreads from the child root to the parent, node 2 ceases to exist, and two new nodes are created on the parent root, either side of node 1.
- Fungal node 4 passes branch node 5. A node must be added to the child root to mark the limit of the lesion (Figure 3).
- Fungal node 4 passes fungal node 6. Depending on the behavior of the fungus being modelled, three responses are possible.
 - (i) If the fungal densities indicated by nodes 3 and 6 are the same, consider the lesions to have merged. Nodes 4 and 6 cease to exist.
 - (ii) If the densities differ, remove nodes 4 and 6, and replace them with a node marking the change in density from the upper to the lower lesion.

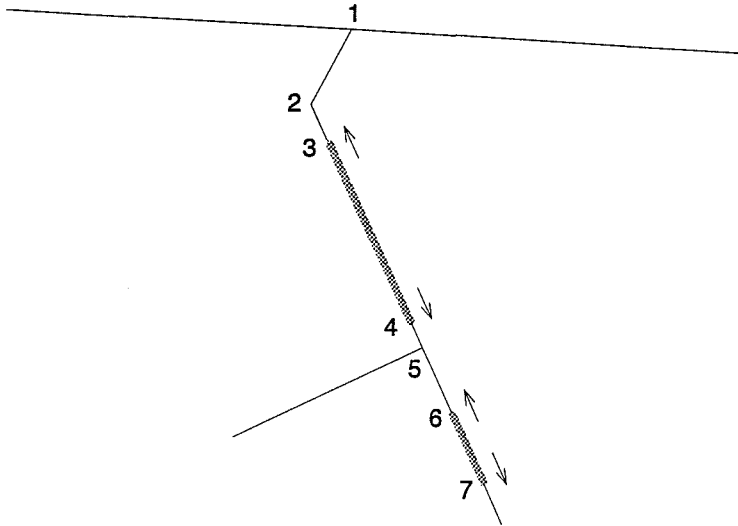

Fig. 7. Fungal lesion expansion.

- (iii) If multiple lesions can exist in the same section of root, allow the lesions to overlap. The fungal density in the internode between nodes 6 and 4 will be the sum of the densities occurring in the individual lesions.

2.9 Root contact

Central to a three-dimensional simulation of root architecture is the ability to detect inter-root contact, roots that are close to each other, and root contact with sources of inocula. An algorithm to determine the shortest route between two internodes is required; the parser / client system described above could be used to locate all colonised internodes, and the client routine could initiate a second parser / client pair to check the distance from each infected internode to every other internode in the root system (including those belonging to other plants). In practice it is far more efficient to employ some form of three-dimensional indexing so that only those internodes known to be reasonably close to the infected internode are checked [5]. The “voxel-lattice” or “oct-tree” techniques applied in the field of three-dimensional computer imaging are directly applicable.

2.10 Infection

Given that a root and a pathogen are in contact, the success or failure of the root’s defense (or the pathogen’s attack) are dependent on a large number of factors. Soil temperature and moisture may play a major role. The three-dimensional nature of the model described here allows a particularly thorough treatment of these depth dependent variables. The physiological status of the

root, nearby fungal populations (both antagonistic and beneficial) and the overall disease loading of the whole root system are all relevant to the infection process. As discussed previously, these factors may also be represented and manipulated by this model (see the *fungi*₁, *fungi*₂ and *fungi*₃ variables in figure 5).

While the algorithm for determining the outcome of a root / pathogen encounter will vary with the system being modelled, in general an “infection score” is a useful decision making tool. A base value, probably defined by the root’s physiological stage, can be increased or decreased by temperature, moisture, pathogen vigour, pathogen density, or other relevant factors. Populations of species antagonistic to the pathogen (biological control agents, for example) could modify the score in the root’s favour. Similarly populations of species known to enhance the pathogen’s impact could be modelled and accounted for. Infection could be considered to occur if the score exceeded some predefined critical value.

2.11 Other spatial effects

The three-dimensional nature of this model allows other spatially variable components of the plant root ecosystem to be examined. Soil nutrient levels could be represented as a lattice of rectangular volumes. The initial distribution of nutrients within this lattice, and changes in nutrient levels caused by roots and fertiliser inputs could be examined; a root system’s efficiency of exploitation of a soil volume, or root competition, both intra- and inter-species, could be examined.

Ground topography, another facet of some soil root ecosystems, can also be considered. Henderson *et al.* [11] incorporated root response to soil surface planes in furrowed Sitka spruce planting. Figure 8, from the *Pinus radiata* / *Armillaria spp.* pathosystem implementation of this model, illustrates a ground topography which varies at a scale that would have an effect on a root system.

3 Results

As discussed in [4] and [6], the form of validation appropriate to a specific application of this model would depend on the application itself. In this section results from an application of the model to the *Pinus radiata* / *armillaria* pathosystem are presented with field observations.

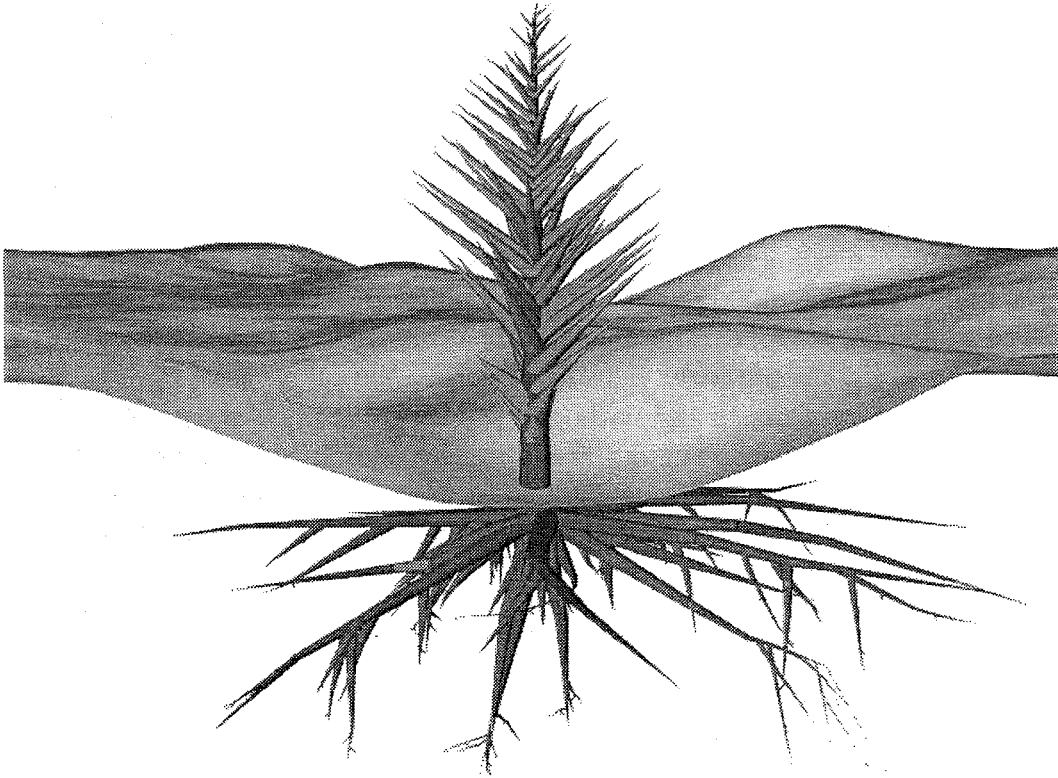

Fig. 8. A ray-traced image of a simulated *Pinus spp.* root system and ground topography.

3.1 Disease spread

Figure 9 is a field observation of armillaria in a North American lodgepole pine stand generously made available by Zeglen [21]. Figure 10 is simulation output for a radial expansion scenario. While figure 9 represents a steady state condition and figure 10 is part of a developing disease centre, the similarity of armillaria distribution is notable, particularly in the existence of infection foci around root collars.

Figure 10 also illustrates the model's ability to represent disease centre expansion, an important feature of the armillaria pathosystem in New Zealand. Typically areas of high fatality in establishing *Pinus radiata* plantations will be focused on dead root systems of either native tree species or mature *P. radiata* from the previous crop. The interpretation of the pattern of development of these centres is unclear [14,16,19], but the ability of the small scale processes included in the simulation model to predict such a large scale effect suggests an appropriate set of small scale mechanisms has been included in the model.

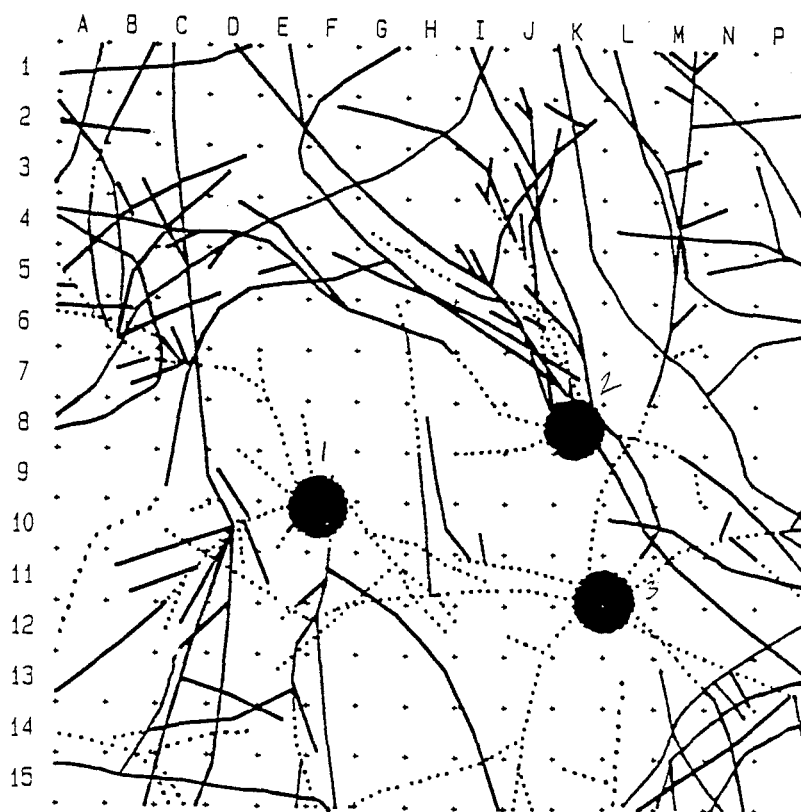

Fig. 9. Armillaria distribution in a lodgepole pine stand, steady state in a North American forest. Dotted lines represent infection.

3.2 Thinning effect

For the situation illustrated in Figure 11, where thinning creates a dead root system between infected and uninfected trees, the actual impact of thinning is variable. Thinning may cause infection of tree C, by providing a path of lessened resistance, assuming recently killed roots are more susceptible to armillaria than actively growing roots. Thinning may prevent infection of tree C by terminating root extension and eliminating contact between either trees A and B or B and C. Thinning may have no effect on disease spread, if, regardless of thinning, no contact occurs between A and B or B and C, or if A comes into direct contact with C.

Repeated simulation runs for the system described in figure 11 gave each of the possible outcomes, i.e. positive, negative and neutral impact on disease spread. This result not only re-confirms the model's ability to represent events in the field, but also lends weight to the use of detailed stochastic models of real

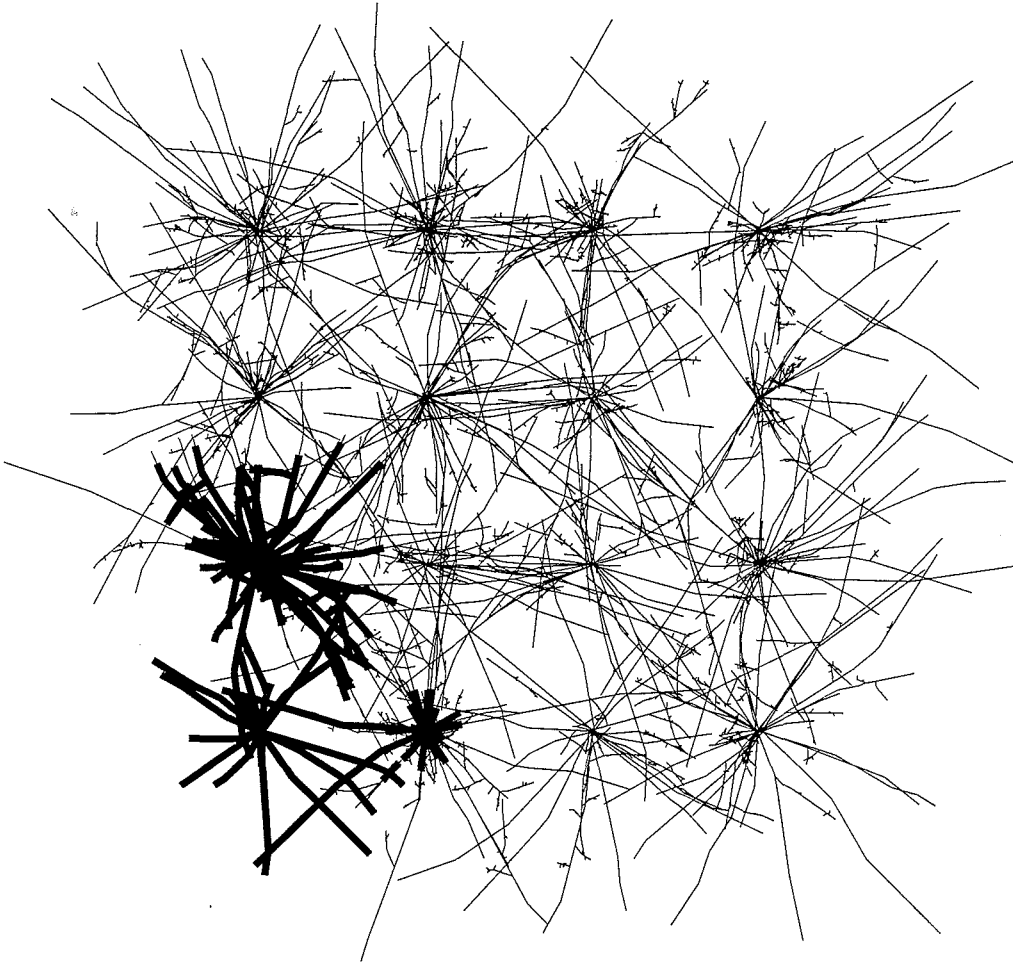

Fig. 10. Simulation output for disease centre expansion. Bold lines represent infection.

physical entities. Many simpler density / probability based models may be able to predict only one or perhaps two possible outcomes in a scenario such as thinning impact on disease spread.

3.3 *Biological control agent effect*

Hill has demonstrated effective protection of young *P. radiata* from armillaria by inoculations of the root system with *Trichoderma spp.* as a biological control agent (BCA) [8]. The simulation model's representation of fungal populations allows this exclusion effect to be modelled. Figure 12 illustrates the projected final extents of, from left to right, armillaria infected, *Trichoderma spp.* inoculated, and fungi-free root systems. Re-running the simulation with and without the *Trichoderma spp.* indicated the possibility of the BCA being

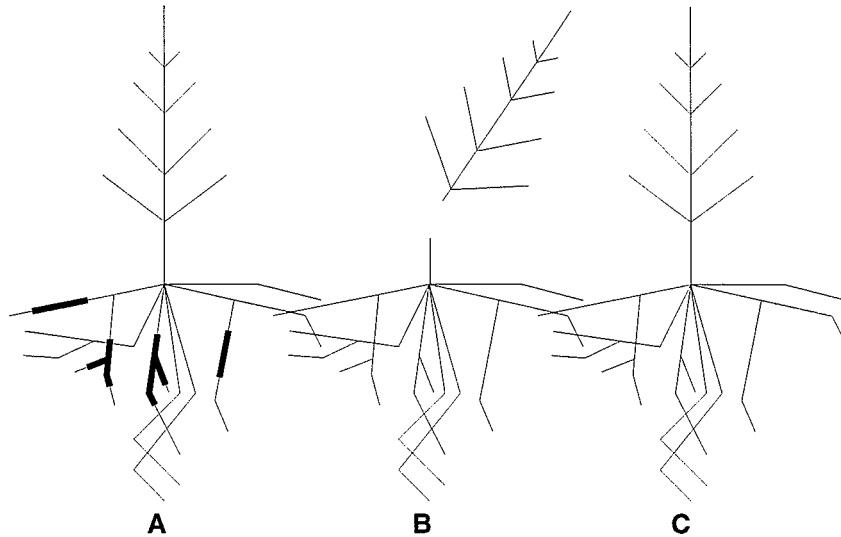

Fig. 11. Thinning adjacent to a diseased root system. Bold lines represent infection. temporally and spatially coincident with the point of contact between armillaria and the uninfected root system. This type of prediction may be useful in assessing the potential for the successful transfer of inhibitory interactions found in the laboratory to the field.

4 Discussion

To be of maximum benefit to an experimental program, a simulation model should be developed in parallel to, if not before, extensive field work. To facilitate this, a flexible system which includes built-in functions to deal with the more demanding implementation problems, in this case root morphology simulation, has obvious applications. The model described here is seen as a core for a root microbial ecology simulation system that can be easily adapted to different ecosystems.

The level of flexibility envisaged is high; for instance it should be possible to develop a scripting language that supports the creation of arbitrary ecosystem parameters. Take the hypothetical example of a low phosphorus soil in which plant disease resistance is improved by increased plant tissue phosphorus levels, which can be conferred by a mycorrhizal fungus. Even without any provision for this situation in the simulation code proper, a fully fledged generic simulation framework could allow the definition of an abstract "resource" or "substance" variable. The value could then be modified by mycorrhizal biomass, which would be modelled by the simulation, allowing the value to be included in the rule that was defined to determine the outcome of plant / pathogen interactions. For purely illustrative purposes, the following

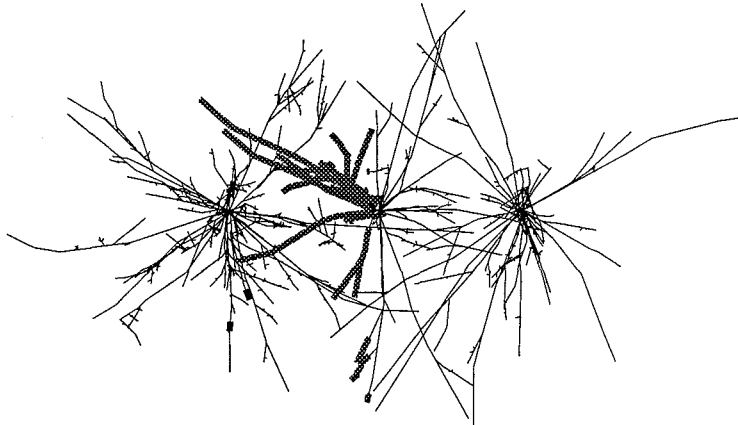

Fig. 12. Simulation of *Trichoderma spp.* as a biological control agent. Bold shaded lines indicate roots in soil occupied by trichoderma.

speculative configuration script fragment outlines the above procedure:

```
substance plant.phos = 1.
```

Define a new variable, called "plant.phos".

```
plant.phos = plant.phos + biomass(myc) / 0.25
```

Modify with mycorrhizal biomass, a predefined function.

```
plant.resist = plant.resist + 0.15 * plant.phos
```

Use the variable `plant.phos` to modify another variable, `plant.resist`, which is compared with another variable, say `phytophthora.virulence`, to determine if a plant / pathogen encounter (predicted by the root architecture component of the simulation) results in infection.

4.1 Implementation

The model described here has been implemented for the *Pinus radiata* / *Armillaria spp.* pathosystem [5] in the C programming language, and is currently being re-implemented in a generic form in the C++ programming language. The object oriented paradigm supported by C++ is well suited to the node based representation. Issues such as indexing algorithms to accelerate the calculation of inter-root distances and human / computer readable forms of the stochastic function matrix have been addressed previously [5]. Visualisation capabilities are also an important part of an implementation of the model; the complexity of plant root systems means that verification during the models development and interpretation of results is difficult unless a versatile three-dimensional graphical interface is available. Figure 8 illustrates the realistic output possible with current computer graphic methods. This level of realism allows rapid interpretation of model output, and also highlights any errors in the simulation's formulation or implementation.

An additional type of node may also be useful for visualisation and result generation. "Probe" nodes could be placed at points of interest, either by the root system construction routine, or by the user via the graphical interface. These nodes could then respond with values such as fungal density when the root system is parsed by a report generating routine.

4.2 Further Development

Complex, stochastic systems like plant root morphologies are difficult to characterise and compare, and so models of such systems are difficult to validate. Brown [6,4] considered some possible objective indices of root system form, and developed a root radial distribution index [7]. Such system specific indices allow model output to be compared with field observations, although the cost of obtaining the latter means that high variability remains a problem. However, models based on the model presented here may be useful in cases where the general nature (weak positive, strong negative and so on) of an ecosystem's response to a change is of interest. Tsegaye *et al.* [18] illustrated this type of model application using the ROOTMAP model of Diggle [9]. The possibility of root mediated soil drying causing increased penetration resistance and consequent reduction in overall root system size was confirmed by ROOTMAP's output. Appendix A illustrates our model's ability to represent some diverse phenomena observed in the field, and its ability to predict events caused by those phenomena.

A useful feature of detailed spatial models is that they may be "sampled" in

the same way as their real world counterparts. For example, core sampling, a field technique often applied to root systems, may be performed on the simulated root architecture by defining the position of a cylinder, and performing the appropriate calculations on each internode. Trench wall intercept data may be obtained in a similar manner [1]. The ability to carry out such “virtual” sampling has two advantages; it allows the simulated architecture to be compared with commonly available measurements that do not directly describe root morphology, and it allows the sampling techniques themselves to be assessed. For example, the correlation of limited core sampling data with total root length may be accurately determined, as the true total root length of the simulated system may be easily calculated. Alternate patterns of core sampling may be assessed without the time consuming collection and extraction normally required.

An early goal in the continued development of the system would be the specification of a generic root architecture description syntax that allowed easy modification by users with only a limited background in computing, but still permitted the representation of complex root system features. An entry format that allows the root system to be described in natural terms would probably be most successful, although some mathematical abstractions are unavoidable.

4.3 Conclusion

Simulation of systems from a low level, real entity or mechanism basis is becoming increasingly common as computing resources become more readily available. Finite element analysis and similar methodologies are popular in physical and engineering fields, molecular and even atomic level simulations are common in chemical and molecular biology research. The initial overhead in implementing these low level models makes them practical only if a generic, re-usable toolkit capable of representing the systems’ basic structure is available. It seems reasonable that, particularly in cases where spatial relationships and spatial heterogeneity are important, similar low level, real entity based simulations may be useful in ecology. The model described here is suitable to form the basis for such a toolkit for plant root microbial ecosystem simulation applications.

References

- [1] A.G. Bengough, C.J. Mackenzie, and A.J. Diggle. Relations between root length densities and root intersections with horizontal and vertical planes using root growth modelling in 3-dimensions. *Plant and Soil*, 145:245–252, 1992.

- [2] W.J. Bloomberg. A model of damping off and root rot of Douglas fir seedlings caused by *Fusarium oxysporum*. *Phytopathology*, 69(1):74–81, 1979.
- [3] W.J. Bloomberg. Model simulations of infection of Douglas fir seedlings by *Fusarium oxysporum*. *Phytopathology*, 69(10):1072–1077, 1979.
- [4] T.N. Brown. *Simulation of the development of the Root System and associated Microbial Community of Pinus radiata*. PhD thesis, Lincoln University, Centre for Computing and Biometrics, 1995.
- [5] T.N. Brown and D. Kulasiri. Simulation of *Pinus radiata* root system structure for ecosystem management applications. *Simulation*, 62(5):286–294, 1994.
- [6] T.N. Brown and D. Kulasiri. Validating models of complex, stochastic, biological systems. *Ecological Modelling*, 86:129–134, 1996.
- [7] T.N. Brown, D. Kulasiri, and R. Gaunt. An objective index for the radial distribution of low order lateral tree roots. *New Zealand Journal of Forestry Science*, in press, 1996.
- [8] H.G. Cutler and R.A. Hill. Natural fungicides and their delivery systems as alternatives to synthetics. In C.L. Wilson and M.E. Wisniewski, editors, *Biological Control of Postharvest Diseases. Theory and Practice*, chapter 12, pages 135–152. CRC Press Inc., London, 1994.
- [9] A.J. Diggle. ROOTMAP – a model in three-dimensional coordinates of the growth and structure of fibrous root systems. *Plant and Soil*, 105:169–178, 1988.
- [10] A.H. Fitter, T.R. Stickland, M.L. Harvey, and G.W. Wilson. Architectural analysis of plant root systems 1. Architectural correlates of exploitation efficiency. *New Phytologist*, 118:375–382, 1991.
- [11] R. Henderson, E.D. Ford, and E. Renshaw. Morphology of the structural root system of Sitka spruce: 2. Computer simulation of rooting patterns. *Forestry*, 56(2):137–153, 1983.
- [12] R. Henderson, E.D. Ford, E. Renshaw, and J.D. Deans. Morphology of the structural root system of Sitka spruce: 1. Analysis and quantitative description. *Forestry*, 56(2):121–135, 1983.
- [13] D.R. Lungley. The growth of root systems, a numerical computer simulation model. *Plant and Soil*, 38:145–159, 1973.
- [14] M. MacKenzie and C.G. Shaw III. Spatial relationships between armillaria root rot of *Pinus radiata* seedlings and the stumps of indigenous trees. *New Zealand Journal of Forestry Science*, 7(3):374–383, 1977.
- [15] K.M. Reynolds. Simulation and spread of *Phytophthora cinnamomi* causing a root rot of Fraser fir in nursery beds. *Phytopathology*, 76(11):1190–1201, 1986.

- [16] L.F. Roth, C.G. Shaw III, M. MacKenzie, and F. Crockett. Early patterns of armillaria root rot in New Zealand pine plantations converted from indigenous forest - an alternative interpretation. *New Zealand Journal of Forestry Science*, 9(3):316–323, 1979.
- [17] T.M. Schlichter, R.R. Van der Ploeg, and B. Ulrich. A simulation model of the water uptake of a beech forest: testing variations in root biomass and distribution. *Zeitschrift fur Pflanzenernahrung und Bodenkunde*, 146(6):725–735, 1983.
- [18] T. Tsegaye, C.E. Mullins, and A.J. Diggle. Modelling pea (*Pisum sativum*) root growth in drying soil. a comparison between observations and model predictions. *New Phytologist*, 131:179–189, 1995.
- [19] J.B. van der Pas, I.A. Hood, and M. McKenzie. Armillaria root rot. Forest pathology in New Zealand leaflet series 4, 1983.
- [20] A. Watson and C. O’Loughlin. Structural root morphology and biomass of three age-classes of *Pinus radiata*. *New Zealand Journal of Forestry Science*, 20(1):97–110, 1990.
- [21] S. Zeglen. An investigation of armillaria root disease in a lodgepole pine stand. Master’s thesis, Utah State University, 1991.