

NEW ZEALAND AGRICULTURAL ENGINEERING INSTITUTE

New Zealand Agricultural Engineering Institute  
Lincoln College

**FARM**

**ENGINEERING**

**TOPICS 1**

**Trials With Trickle Irrigation**

EXTENSION BULLETIN

E/5

# **FARM ENGINEERING TOPICS**

## **Trials With Trickle Irrigation**

**J. S. DUNN**

**October 1970**

**An Extension Bulletin of the New Zealand Agricultural  
Engineering Institute, Lincoln College,  
University of Canterbury, New Zealand**

**E/5**

## CONTENTS

|   | Page |
|---|------|
| Trials with Trickle Irrigation                                      | 1    |
| Use of design graphs  | 12   |
| Graph 1 - Pressure/discharge for nominal 0.20in diameter microtube  | 13   |
| Graph 2 - Pressure/discharge for nominal 0.035in diameter microtube | 14   |
| Graph 3 - Pressure/length for nominal 0.20in diameter microtube     | 15   |
| Graph 4 - Pressure/length for nominal 0.035in diameter microtube    | 16   |

Some of this material was first printed in the N. Z. Farmer

# **Trials With Trickle Irrigation**

## **INTRODUCTION**

The trickle system of irrigation, used successfully for a number of years in glasshouse cropping, has been simplified for use on a field scale.

The work was started by Symcha Blass in Israel in 1962 and its application has already reached Australia.

The system has been used under New Zealand conditions by the N. Z. Agricultural Engineering Institute, at Lincoln College, during the past season and it is showing considerable promise.

Pressures and flow rates are much below those used in conventional irrigation systems so that capital investment in pumps and supply mains is appreciably less.

Overall water use is considerably reduced by eliminating evaporative losses during application and supplying only the plants' exact requirements. In this way, water sources normally considered too small for irrigation may be used.

The complete reticulation system for trickle consists of commercial grade, low density polythene pipe and the simple methods of jointing eliminate the need for any proprietary fittings.

## **DESCRIPTION**

The basic components of the system are a header pipe of  $1\frac{1}{2}$  or 2in diameter, laterals of  $\frac{1}{2}$ in diameter which are inserted into the header pipe at intervals, and small-diameter micro-tubes or "whiskers" of 20 to 35 thousandths of an inch internal diameter inserted into the laterals.

The small bore of the whisker restricts the rate at which water can leave the lateral, but the degree of restriction depends on the length of the whisker. A long whisker severely restricts the flow, but by shortening it, the flow rate can be increased. In this way, for any pressure, a wide range of delivery rates can be obtained.

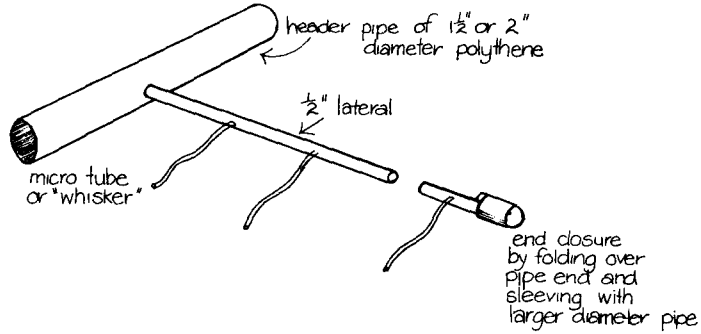

Diagram 1  
Basic components of trickle irrigation

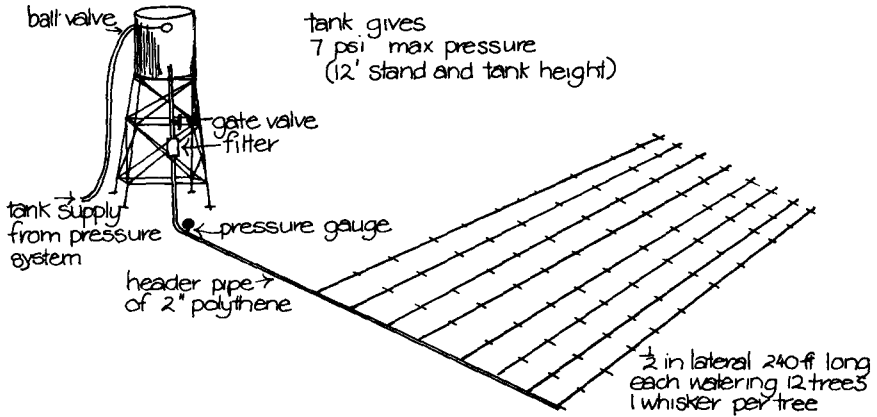

Diagram 2  
Layout of one-acre trial area in Loburn orchard

As the reverse is also true, we have a simple means of accommodating varying pressures along the lateral to ensure a uniform delivery from each whisker in it. Undulating country can therefore be irrigated with a high degree of uniformity without the use of flow control valves or juggling with different pipe diameters; and long laterals need no longer result in poor watering at the ends farthest from the supply.

Laterals are connected to the header pipe by inserting them with a screwing action into holes drilled with a sharp wood bit. The hole should have a diameter 1/16in less than the outside diameter of the lateral. To ensure a good fit it is advisable to check the diameter of each batch of lateral pipe. Some variation does occur in the pipe from different manufacturers. A depth stop on the bit will prevent it penetrating the far side of the pipe.

Whisker insertion uses a slightly different technique, but again makes use of the elastic properties of polythene. A circular hole slightly less than the outside diameter of the whisker is punched in the lateral wall and expanded by the enlarged shank of the punch as it enters further. The whisker can be inserted easily immediately after removing the punch, but it is soon gripped as the hole contracts. A hole may be temporarily enlarged to replace any whisker by slightly bending the lateral in the vicinity of the hole.

Header and lateral pipes are closed by doubling over the end 6 to 12in of the pipe and either pushing on a short sleeve of slightly larger diameter pipe or by tying with string.

Israeli and Australian work has been concerned with pressures of  $7\frac{1}{2}$  to 30 psi, although 15 psi is normally recommended. Much lower pressures have been used in the NZAEI investigations mainly because higher pressure sources were not available. These have proved quite satisfactory.

## **ORCHARD WORK**

Plots in two apple orchards have been trickle irrigated by watering each tree with one whisker at a rate of 1 gal a tree an hour (32 thou diameter whiskers, 20in long, at a pressure of 6 to 7 psi).

One plot of approximately 1 acre was watered adequately with a flow of 96 gal an hour (96 Delicious and Golden Delicious trees at a 20ft x 20ft planting distance.) A profile dug alongside one of the trees indicated a wetted zone as shown in diagram 3 after 120 hours

of continuous watering. As a severe water deficiency had been made good at the end of this period, further watering was reduced to 12 hours a day.

Plots of peas, freezing beans, sprouts, cauliflowers, sprouting broccoli, cabbage, carrots, parsnips, beetroot, silver beet, onions, leeks, asparagus and sweet corn were watered by trickle during the 1969-70 season.

Each plot was five 20in rows wide and 250ft long. Four 250ft laterals were used with 113 whiskers at 2ft intervals in each.

The water source was a T-piece inserted into a  $\frac{3}{4}$ in sheep trough supply. This had a no-flow pressure of 13 psi and, on supply, delivered 2.8 gal a minute at 3 to 4 psi. The output from each whisker was approximately  $\frac{1}{3}$  gal an hour.

The surface wetted zone around each whisker had a diameter of about 24in on a well-worked seed bed, so laterals were run between alternate rows.

With only four laterals in use, frequent moving was necessary to water the whole cropped area. This was done quickly and easily once every 24 hours. The laterals and whiskers handled well and suffered no damage through the season.

The response of lucerne to trickle in the drought conditions of 1969-70 was dramatic and a width of 8 to 9ft was stimulated into growth when one of the 250ft vegetable laterals was run for a 60-hour period.

With this knowledge, a harness of five 250ft laterals, each 6ft apart, was made up so that  $\frac{1}{6}$  acre could be watered at a time.

The sheep trough supply used for the vegetables was capable of supplying enough to apply the equivalent of 1in a day on this area. In 6 days therefore, 1 acre could be watered adequately to cope with normal summer consumption. By moving the harness only every other day, 2 acres could be covered in 2 weeks and a 2in application given at each position.

The harness could be dragged across the paddock by two men although towing with a vehicle was easier. A  $\frac{3}{4}$ in supply hose was used.

This programme was upset when lambs were turned into the paddock. They were particularly interested in the whiskers and

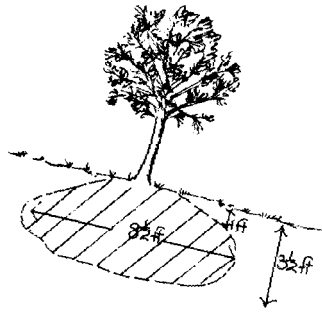

Diagram 3  
Wetted profile under one whisker after  
120 hours running

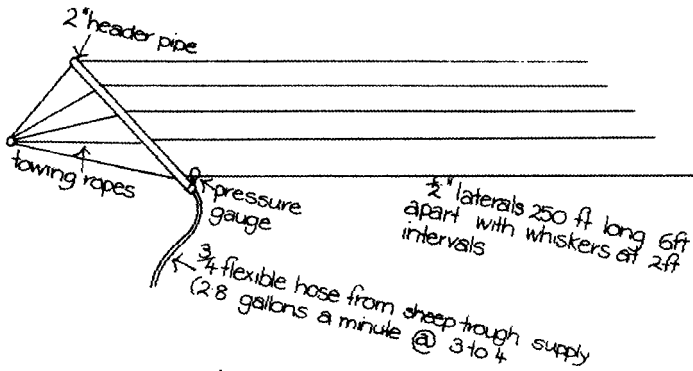

Diagram 4  
Lucerne harness covering one-sixth of  
an acre

most were eaten or badly chewed within 3 days!

Trickle irrigation of grass would require a closer lateral spacing because of the much shallower rooting habit of grass.

## **OTHER CROPS**

Work in raspberries, strawberries, blackcurrants, grapes and boysenberries, for which trickle would seem to be ideally suited, is planned for the 1970-71 season.

No wetting of foliage or fruit would occur and, in the case of strawberries, the whiskers would be inserted beneath the polythene mulch to ensure watering within the ridge.

Trickle irrigation could well find favour with growers of outdoor tomatoes, grapes, tobacco and hops, where overhead irrigation can be detrimental to both plant tissue and soil structure. It could also materially assist in the establishment of young trees when forming shelter belts.

Work overseas has indicated appreciable yield increases in some crops from the use of permanent trickle installations when comparisons are made with sprinkler or flood systems. Daily application to make up the previous day's losses ensures that plants are never subject to the stress which builds up during the 1, 2 or 3-week interval between normal conventional applications.

Fertilizer applications of soluble materials can be made in the trickle system. This is accepted practice in glasshouse tomato culture.

The introduction of soluble nematocides into the rooting zone of trees and shrubs in this way might be of considerable benefit in some circumstances, provided the active ingredients were not phytotoxic.

## **FILTRATION**

Clean water is essential for successful trickle irrigation. Deep well sources have been used in the NZAEI work and no whisker blockages have occurred so far although a filter has been included in only one layout. A simple PVC filter with a low head loss has been developed by the NZAEI for use where supplies are

obtained from open water or other possibly contaminated sources. It is being considered for commercial production.

## **COST**

Present retail prices of  $\frac{1}{2}$ ,  $1\frac{1}{2}$  and 2-inch low-density polythene pipe are 3, 11 and 16 cents a foot, respectively. The small bore whisker tubing is approximately  $\frac{1}{2}$  cent a foot.

To install a permanent system in an orchard at a 20ft x 20ft tree spacing (8 laterals of 12 trees each with the necessary header pipe) would cost approximately \$75 an acre for materials. An acre of blackcurrants at a 7ft row spacing would cost about three times this amount. The lucerne harness described would cost \$45.

The benefits of the trickle system of watering are considerable and its use can be expected to grow rapidly. However, as with all irrigation systems, any layout must be tailored to suit each specific situation and an understanding of the basic principles of irrigation is still necessary if the maximum benefits are to be gained.



This unusual pattern resulted on lucerne trickle irrigated for 60 hours. The 8ft-wide strip of lucerne was photographed three weeks after the trickle application.



Sweet corn grown with and without  
trickle irrigation.

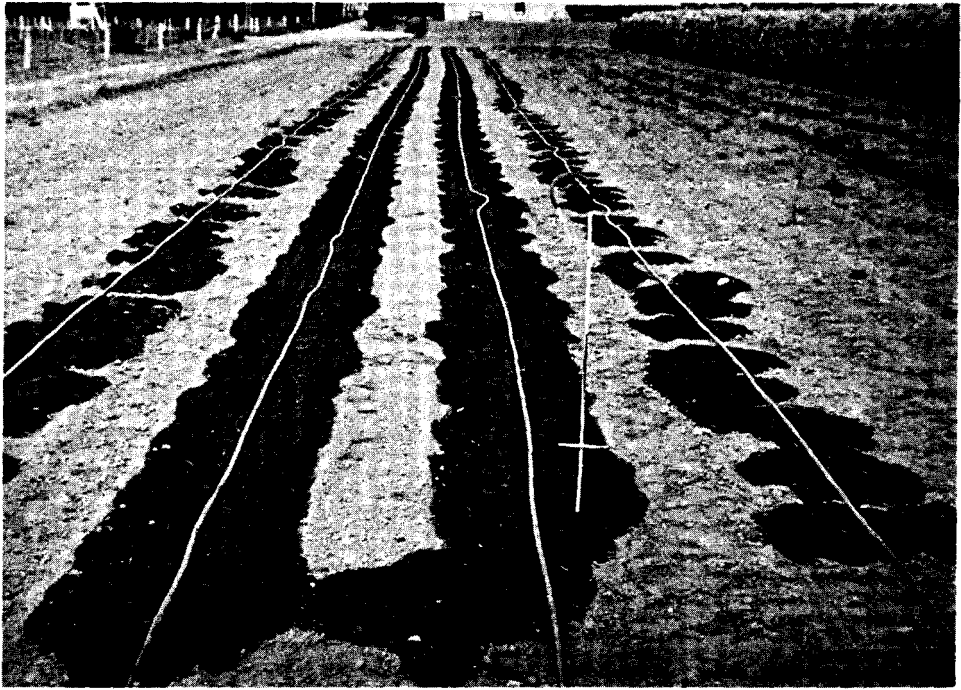

The amount of surface wetting after 16 hours' running on a prepared seed bed. The  $\frac{1}{2}$  in lateral pipes are 250ft long with outlets at 2ft intervals for the "whiskers" - the 0.032in internal diameter pipe, each 20in long. At a pressure of 3 to 4 psi, the flow from each whisker was  $\frac{1}{3}$  gal an hour.



An output of a gallon an hour is being delivered by this 20 inch length of 0.032in diameter whisker. The operating pressure is 6 to 7 psi.

## DESIGN GRAPHS

These graphs have been produced to indicate the pressure/length/output relationship of the nominal 0.020 and 0.035 inch micro-tube or whisker material being used in trickle irrigation installations in New Zealand.

The pressure/discharge curves show the discharge in gallons per hour for different lengths of whisker (from 6 to 30 inches) when supplied at pressures of up to 45 foot head (1 foot head = 0.435 psi or 1 psi = 2.3 foot head).

Derived from these are the pressure/length curves which are used when determining the correct whisker length needed to obtain a constant discharge at each outlet. This is particularly important in an installation on undulating ground where in-line pressures will vary due to changes in contour.

Pipe friction need not be considered except where very long laterals or many closely spaced whiskers are being used.

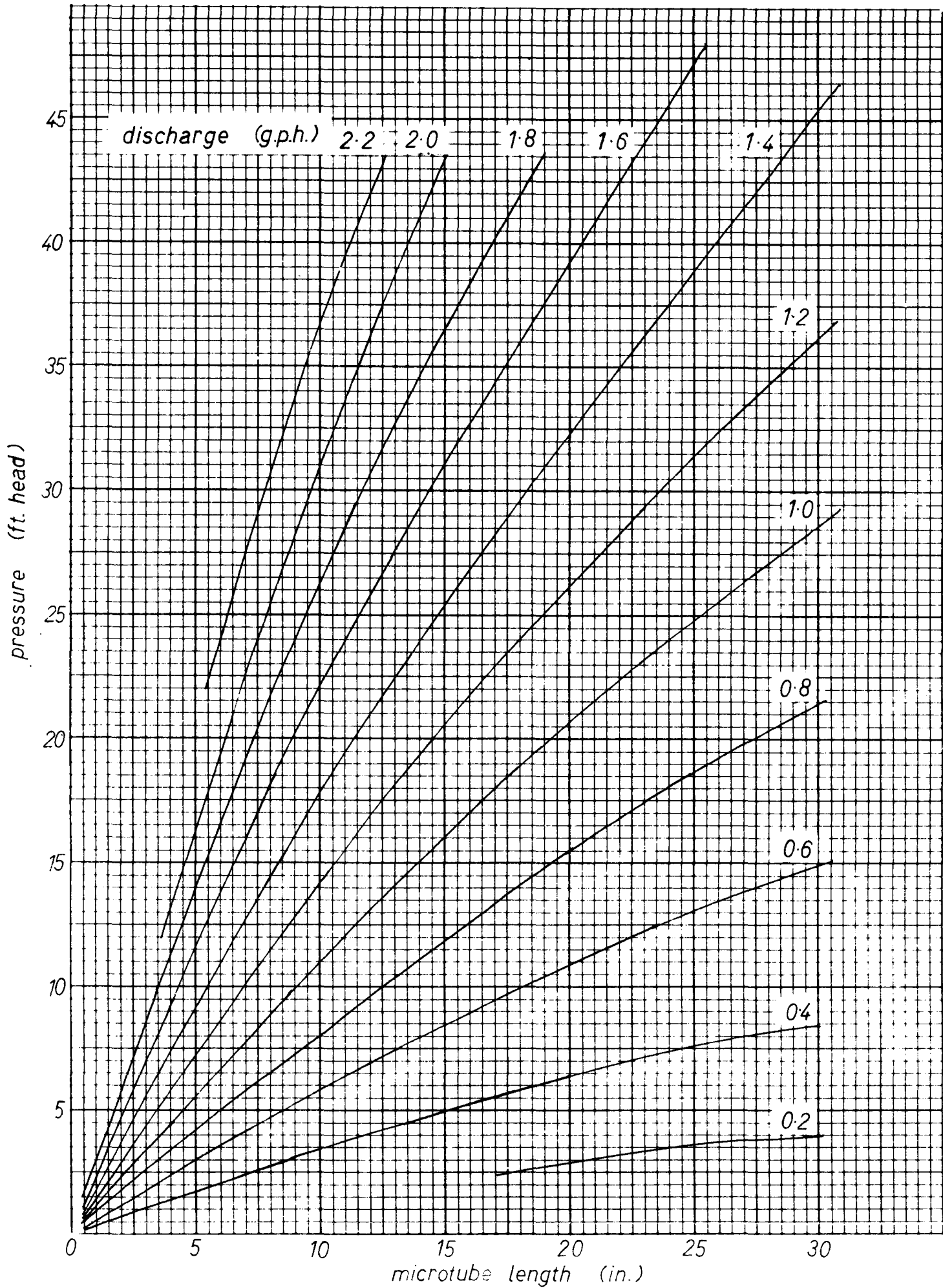

PRESSURE-LENGTH CURVES  
for nominal  
0.035 DIAM. MICROTUBE

N.Z.A.E.I.  
LINCOLN COLLEGE

D.J.KING 9/9/70

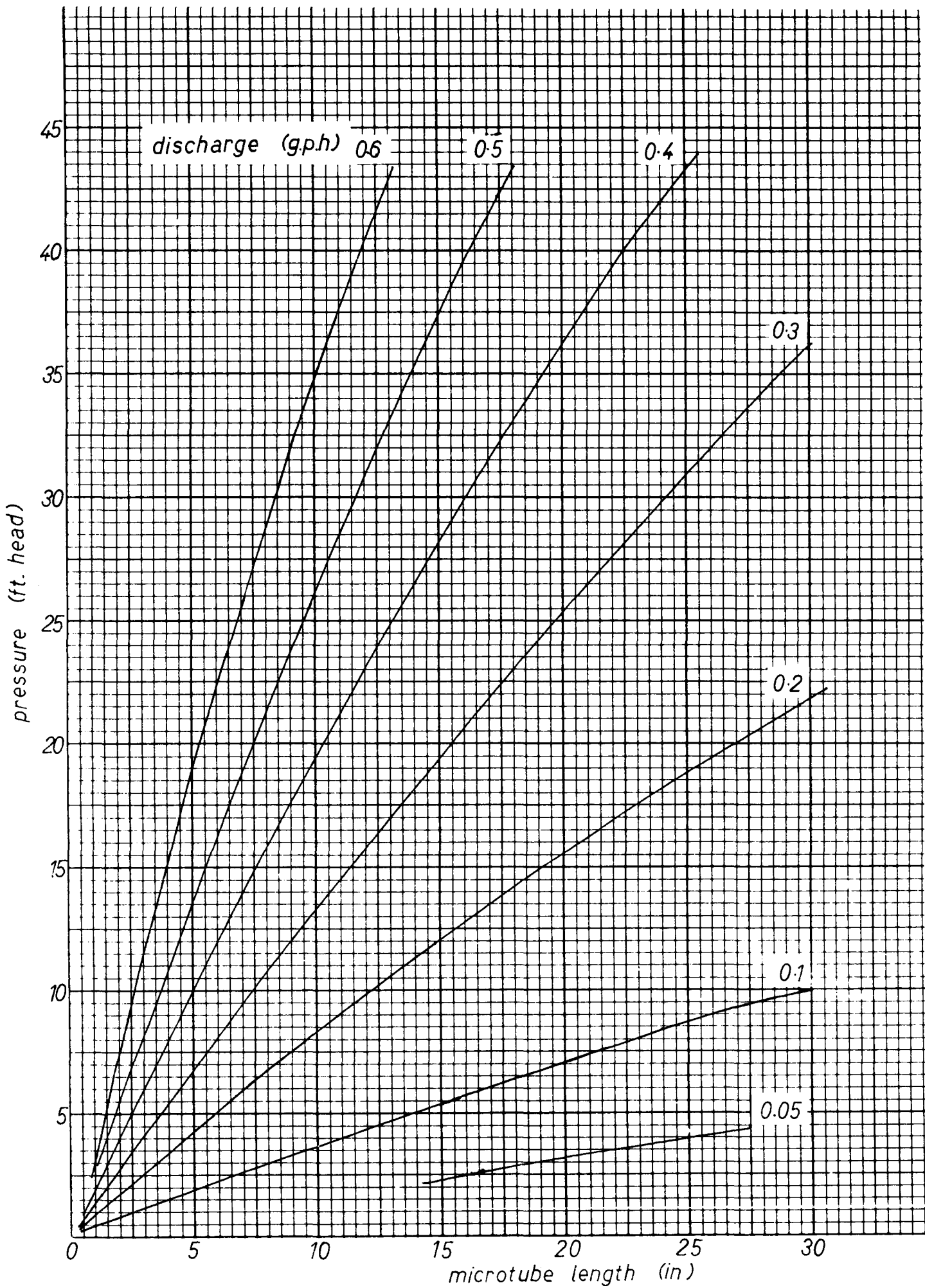

PRESSURE-LENGTH CURVES  
for nominal  
0.020 DIAM. MICROTUBE

N.Z.A.E.I.  
LINCOLN COLLEGE

D.J.KING 9/9/7

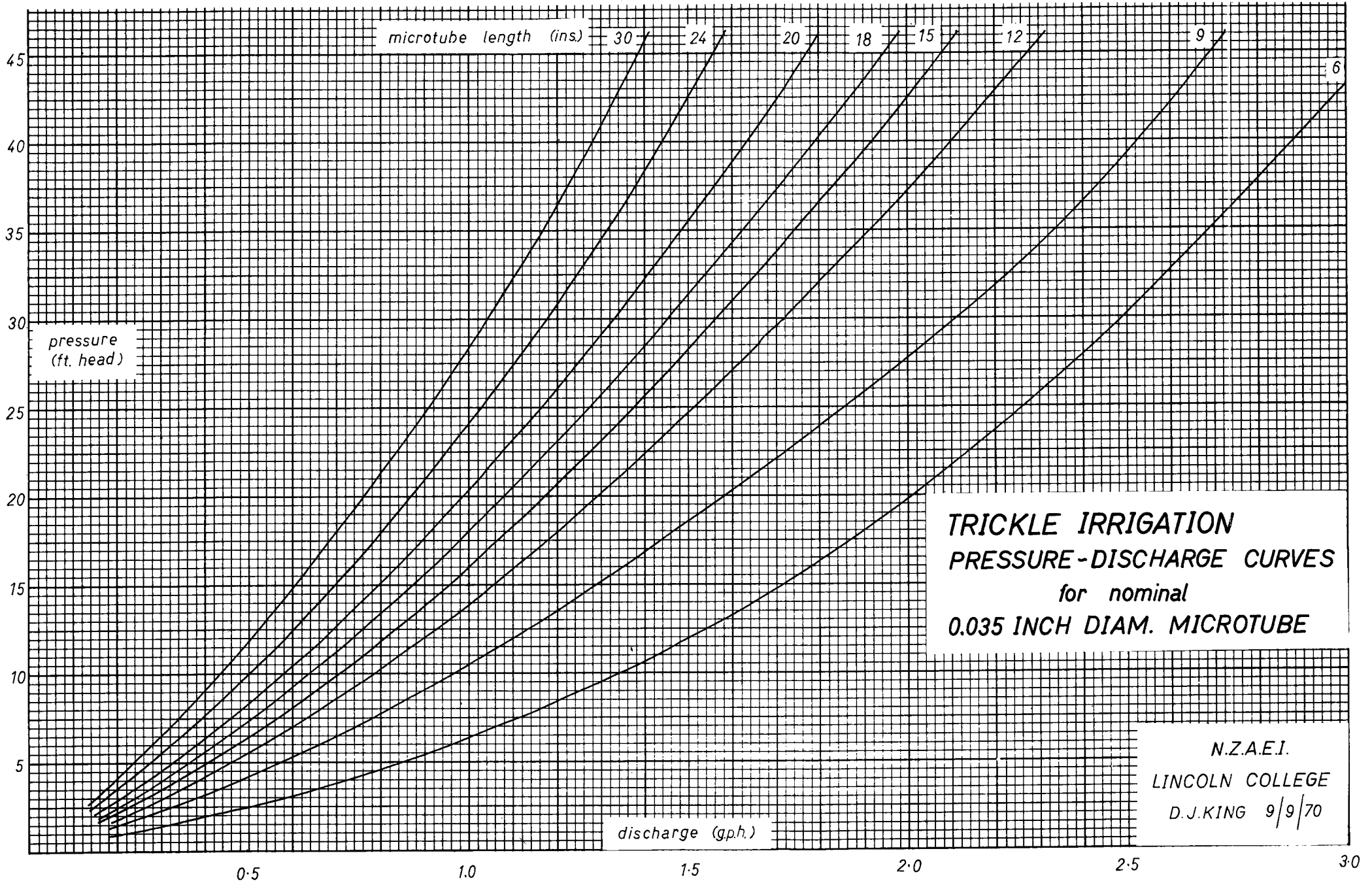

**TRICKLE IRRIGATION  
PRESSURE-DISCHARGE CURVES  
for nominal  
0.035 INCH DIAM. MICROTUBE**

N.Z.A.E.I.  
LINCOLN COLLEGE  
D.J.KING 9/9/70

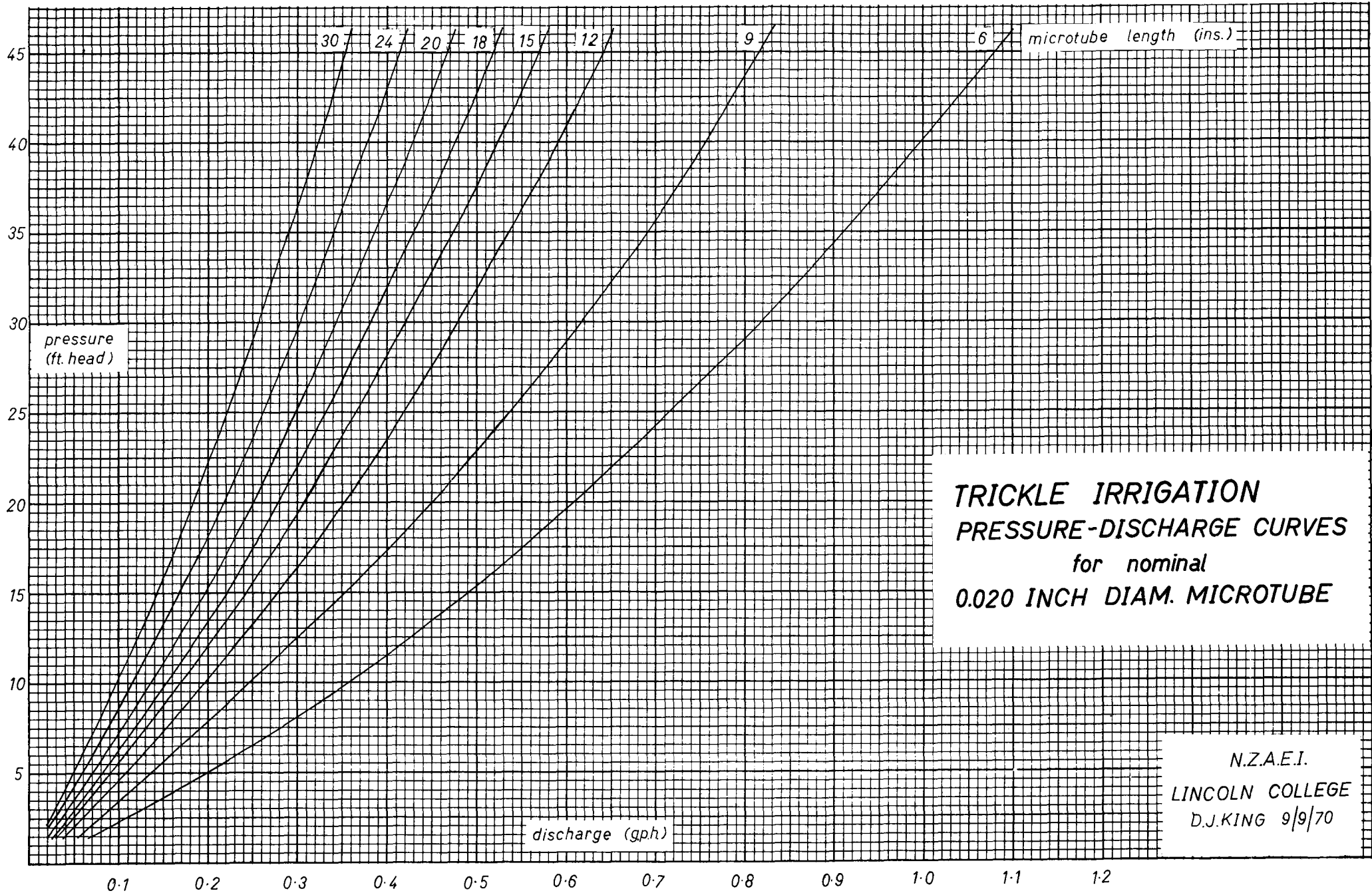

The New Zealand Agricultural Engineering Institute is a government financed organisation established to undertake:

Research and development in the agricultural engineering field.

The testing of agricultural machinery and equipment.

Information and extension activities.

An Institute membership scheme offers a meeting point between the engineering staff and those concerned with practical agricultural engineering. Members receive a copy of each Institute publication.

Affiliate membership is open to private persons for an annual subscription of \$4. Commercial organisations who stand to benefit from the work of the Institute may become associate members on payment of an annual subscription of \$50.