

**THE MEASUREMENT OF SOIL LOSS
FROM FRACTIONAL ACRE PLOTS**

J. A. Hayward



**lincoln papers
in
water resources**

5

THE MEASUREMENT OF SOIL LOSS FROM
FRACTIONAL ACRE PLOTS

J. A. HAYWARD

Lincoln Papers in Water Resources

No. 5 September 1968

A Research Publication of the New Zealand Agricultural Engineering
Institute, Lincoln College, Canterbury, New Zealand

R/6

FOREWORD

Lincoln College, the College of Agriculture of the University of Canterbury, sponsors an active research and teaching programme in hydrology, soil conservation and water resources development. The purpose of these Papers is to communicate research results and new developments in these fields as rapidly as possible, and particularly to report the results of projects undertaken in conjunction by the Department of Agricultural Engineering and the New Zealand Agricultural Engineering Institute. From time to time the opportunity will be taken to publish material originating elsewhere in New Zealand with which the College is associated and which could not otherwise be made available.

The Lincoln Papers in Water Resources are published by the New Zealand Agricultural Engineering Institute and printed by the Lincoln College Press. All enquiries should be addressed to the Information Officer, New Zealand Agricultural Engineering Institute, Lincoln College Post Office, Canterbury, New Zealand.

PREFACE

During the 1920's and 1930's the United States had a massive problem of erosion of arable land. Uhland (1935) showed the extent of the problem when he reported that 35 million acres of land had been ruined, and a further 125 million acres had lost all its topsoil but was still under cultivation. In addition another 100 million acres was actively eroding and in need of remedial treatments.

Those who concerned themselves with the problems of erosion had two tasks. The first was to convince the American people that erosion was a national problem. The second was to develop research procedures to measure erosion and assess the effectiveness of various preventative measures.

Lowdermilk (1931) searched the European literature from the 1850's for studies which attempted to evaluate the factors influencing soil loss and surface water runoff. He found that where studies tried to explain one watershed factor in terms of stream flow, (itself the resultant of many factors) the results were invariably confused. "To avoid the perpetration of this type of confusion experimentation was begun to isolate various factors at work, to measure their influences separately, and later to synthesise and trace the influences of these factors into larger ... watersheds ... The runoff plot was adopted in place of the watershed as the unit of experimentation."

Earlier, in 1917, Dr F.L. Miller of the University of Missouri had established a plot study and with Dr F.L. Duley developed the basic methodology of the runoff plot. It was these to which Lowdermilk referred and in the 1930's many plot studies were started throughout the United States. Since that time it has become firmly established as a research method and although the equipment has been refined and improved, the basic methodology remains substantially unchanged.

Unfortunately, in the fifty years during which these plots have been used, they have never been the subject of critical examination or appraisal. Even contemporary papers and texts accept without question the suitability of run-plots for erosion research.*

This publication draws attention to the two different but related fields in which plots have been used and comments on the design and statistical analyses required if satisfactory results are to be obtained. It also notes that despite the use of precision equipment, the plot method can be a comparatively crude technique of hydrological research. There are a number of ways in which data can be biased and before results can be considered convincing these sources of bias must be accounted for.

In our own work we are using plots in the very harsh conditions of a New Zealand alpine catchment.

* See refs 29 and 36.

In this environment the problems of bias and uncertainty are of the utmost importance. While these problems may assume a lesser importance in other areas and in other studies, we consider that they are still applicable and must be considered.

We believe that for runoff plots to have a place in hydrological research in future they must have much stricter experimental designs than they have had in the past.

ABSTRACT OF PAPER

The use of runoff plots in "Observational" and "Experimental" studies is reviewed and discussed. The basic requirements for a sound experimental design in each type of study are described. It is noted that most studies have been inadequately designed. The principal shortcomings have been the absence of replication and randomisation of treatments, and the inherent assumption that bias is unimportant. The paper identifies several possible sources of bias which must be accounted for before plot data can be extrapolated to field conditions. The equipment most commonly used in plot studies is briefly reviewed. It is suggested that the plot method is probably a fairly crude one, and the use of precision equipment may only give precise measurement of inaccurate values.

CONTENTS

	Page
Foreword	v
Preface	vii
Part One - Methods of Study	1
Equipment	2
Experimental design	4
Statistical analysis	15
Extrapolation	19
Summary	25
Part Two - Review of Studies	27
Plant cover	28
Cropping and cultivation	29
Slope steepness and length	31
Rainfall factors	34
Soil conservation practices	35
Soil factors	36
Erosion process	36
Summary and conclusions	38
Bibliography	39

PART I
METHODS OF STUDY

1. EQUIPMENT

Although some plot designs and ancillary equipment have been more popular than others there has been no standard design. In fact the author has found three quarters as many plot designs as there have been studies. Mutchler (1963) has attributed these design differences to the different requirements of each study and the lack of communication between workers.

The plots are usually enclosed by metal or wooden borders which extend six to eight inches into the ground and protrude by six to eight inches. A metal or concrete collection trough at the lower end concentrates surface water runoff and eroded soil to the measuring devices, and storage tanks.

The area covered by each plot has varied from eight square feet (Duley, 1939) to slightly more than one quarter of an acre (Van Doren, Stauffer and Kidder, 1950).

Studies which have attempted to assess losses from arable land have usually been within the range of 0.01 to 0.02 acres. In these the most common plot size has been six feet wide by 72.6 feet long (0.01 acres). However lengths have ranged from six feet (Duley, 1939) to 272 feet (Wiltshire, 1947). In recent years the United States Department of Agriculture have tended to increase plot width in an attempt to overcome border effects (Wischmeier, pers. comm.).

Observational studies* have tended to be smaller. For example, Costin Wimbush and Kerr (1960) used $\frac{1}{750}$ acre plots and Soons (1966) used $\frac{1}{1000}$ acre plots.

While there is no inherent objection to a range of equipment and designs it may not be possible to compare results from dissimilar studies. Comparisons which adjust the results in proportion to the area of each plot, almost certainly ignore boundary effects and may in consequence be invalid.

* Observational Experimental studies are defined on page 4.

Details of design and construction of plot equipment are given by Costin et al (1960); Wiltshire (1947); Garcia, Hickey and Dortignac (1963); Mutchler (1963) and Soons (1966). Mutchler's description is the most comprehensive. In it he gives details of plot design and installation usually associated with Experimental* studies. He has described:

1. Borders around the plot to define the measured area.
2. The collecting equipment to catch and concentrate runoff from the plot.
3. Conveyance equipment to carry runoff to the sampling unit. (This may include a measuring flume with an anti-sedimentation device).
4. The sampling unit to aliquot the soil loss and runoff into manageable quantities. (Although various devices have been used, the most common are the Geib multislot divisor or the Coshocton type rotating slot sampler).
5. Storage tanks to hold aliquot portions of water and soil for analysis.

In contrast, the equipment used by Costin et al (1960) was extremely simple. Runoff and eroded soil were collected in tins (ranging in size from four to 18 gallons depending on the site). The water in each tin was vigorously agitated and subsampled for a sediment determination. It was then baled out and measured. When compared to the precision equipment described by Mutchler, Costin's method appears somewhat crude. However as the runoff plot method incorporates a number of major inaccuracies and deficiencies there may be little value in going to great trouble to obtain precise measurements.

* See page 4

2. EXPERIMENTAL DESIGN

2.1 OBJECT OF STUDY

From a review of the literature (Hayward, 1967) it is apparent that runoff plots have been used for two different but related purposes.

The most common American use of plots has been to evaluate treatments and variables which influence soil loss from cropping lands. New Zealand and Australian experience has included this approach but has also made use of plots to sample the behaviour of a field characteristic with respect to its influence on erosion.

While the two approaches have points of similarity, there are fundamental differences between them. In the former the experimenter establishes his plots, and then imposes a treatment. In the latter the "treatment" is measured where the experimenter finds it. Boughton (1968) broadly divided hydrological research procedures into either Experimental methods or Observational methods. Using his classification the "American" use could be described as Experimental, and the "Australian and New Zealand" use could be described as Observational. The following examples may help to clarify the differences.

Experimental

Dunford (1954) wanted to determine (inter alia) the influence of cattle grazing on surface water runoff and erosion from a bunchgrass sward. Six $\frac{1}{100}$ acre plots were established on a site and numbered consecutively from east to west. They were then divided into two blocks. Plots 1, 2 and 3 were in block A, plots 4, 5 and 6 were in block B. The plots were run without treatments for a calibration period and it was found that while there were no statistically significant differences in runoff between plots in the same block, there were significant differences between blocks. Therefore identical sets of treatments were applied to each block, and randomised among plots within them. This example typifies the Experimental approach to runoff plot studies.



Fig. 1.

Runoff plots at the Moutere Experimental Station
Nelson. An example of an "Experimental" study.

(photo Ministry of Works)

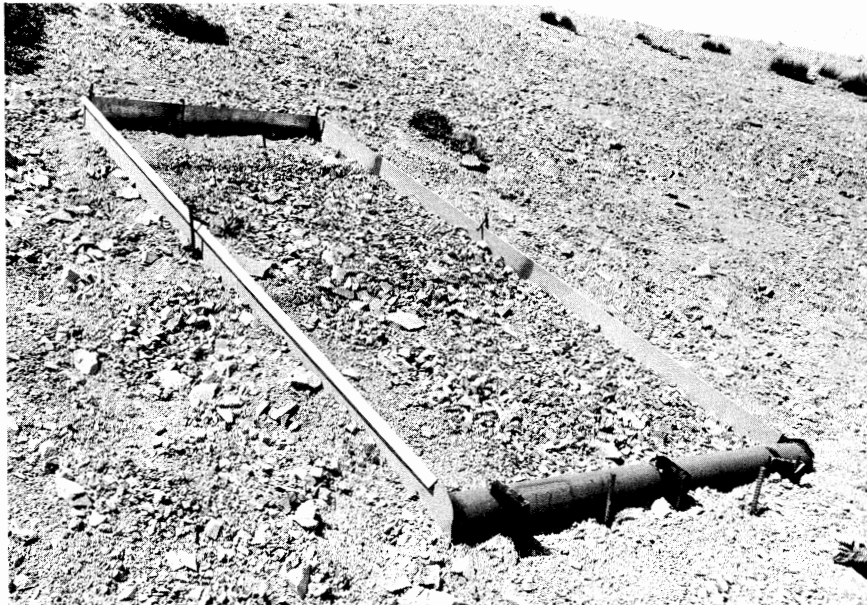

Fig. 2.

A runoff plot at Porter's Pass, Canterbury.
An example of an "Observational" study.

Observational

Costin et al (1960) wanted information about soil loss and surface water runoff from the plant cover types in one area of the Australian Alps. In each of several plant communities a number of plots were established. From the information they obtained off each plot, they predicted the behaviour of each community with respect to its soil and water losses. That is, in this type of study the plots are used to sample the total population of the characteristic under study. From the behaviour of the sample the behaviour of the population is inferred.

Although the design of Costin's experiment had a number of deficiencies, it does provide an example of the observational approach. A subsequent paper in this series will describe the author's Observational study in which plots are used to sample the soil loss behaviour of some plant communities in a New Zealand alpine catchment.

In summary, the essential difference between Experimental and Observational studies is that in the former the experimental design is based on the randomised block procedure, and in the latter it is based on a sampling procedure.

2.2 REPLICATION AND RANDOMISATION OF TREATMENTS

Regardless of whether or not a study is of the Experimental or Observational type, each experiment must be so designed that the differences between treatments can be measured, and the confidence which can be placed in these differences assessed. This implies that every design must incorporate the twin requirements of replication and randomisation. Replication improves the accuracy of the experiment and provides an estimate of the error value of the treatment mean. Randomisation ensures that the error estimate is valid.

Although these essential rules have been employed in agricultural research for many years, runoff plot studies are characterised by their absence. Only one author has

drawn attention to the need for adequate experimental design in plot studies (Brandt, 1941). However, his contribution was incorporated in only four subsequent experiments, and has not been quoted in any of the papers reviewed by this author. The inadequate design of almost all runoff plot experiments means that their results must be approached with caution. At best they are unconvincing, at worst they are misleading.

However, a few exceptions should be noted. For example, Meyer and Mannering (1961) investigated the effect of corn stalk trash on soil and water losses. Each of their six treatments had two replicates and the experiment was laid out on a randomised block design. Dunford (1954) investigated the influence of grazing intensity on soil and water losses and used two replicates of each treatment, in a randomised block design. Although another 19 studies have replicated or partially replicated their treatments the absence of randomisation limits the confidence which can be placed in the results. However Wischmeier (pers. comm.) notes that in recent years most United States Department of Agriculture studies have included replication of treatments in a randomised block design.

2.3 BIAS

Wischmeier, Smith and Uhland (1958) discussed the problem of bias likely to be associated with using data over short time periods.

"(Bias) is usually minimised in good statistical designs by randomisation. But in soil and water loss studies effective randomisation over some of the extraneous variables may not be possible because of physical and economic limitations. For example for soil factor evaluation, it would be difficult to find a range of major soil types within an area compact enough to have identical rainfall."

These appear to be the only authors to have considered the possibility that the data from runoff plots may be biased. Unless the question of bias has been adequately considered, it is not possible to extrapolate or interpret

plot results to field conditions with any degree of confidence.

There are at least two major sources of bias which must be accounted for.

- a. Boundary and microclimate effects introduced by the equipment itself.
- b. The assumptions of homogeneity.

a. Equipment

1. Border interference with overland flow

As most theories of overland flow hold that velocity and depth increase with distance, runoff plots will, other things being equal, tend to underestimate soil and water losses. The importance of this source of bias will depend on the object of study. In "Experimental" studies this bias should be about the same for all treatments. However in "Observational" studies the extent of this bias will vary with plot location. It will tend to be less for plots near the top of a slope and more for those nearer the bottom. Therefore before the results from such a study can be meaningfully discussed or extended beyond the plot this form of bias must be adequately accounted for. The author has, with limited success, attempted to do this by comparing the rates of surface soil movement inside and outside each plot.

2. Leakages into and out of the plot

Another major source of inaccuracy may be caused by the inability to completely seal off the plot from the surrounding land. The author has used water soluble dyes to show that under some conditions surface water from adjacent land, finds its way into the plot, and surface water from the plot may escape underneath the collection trough. (See fig. 1.)

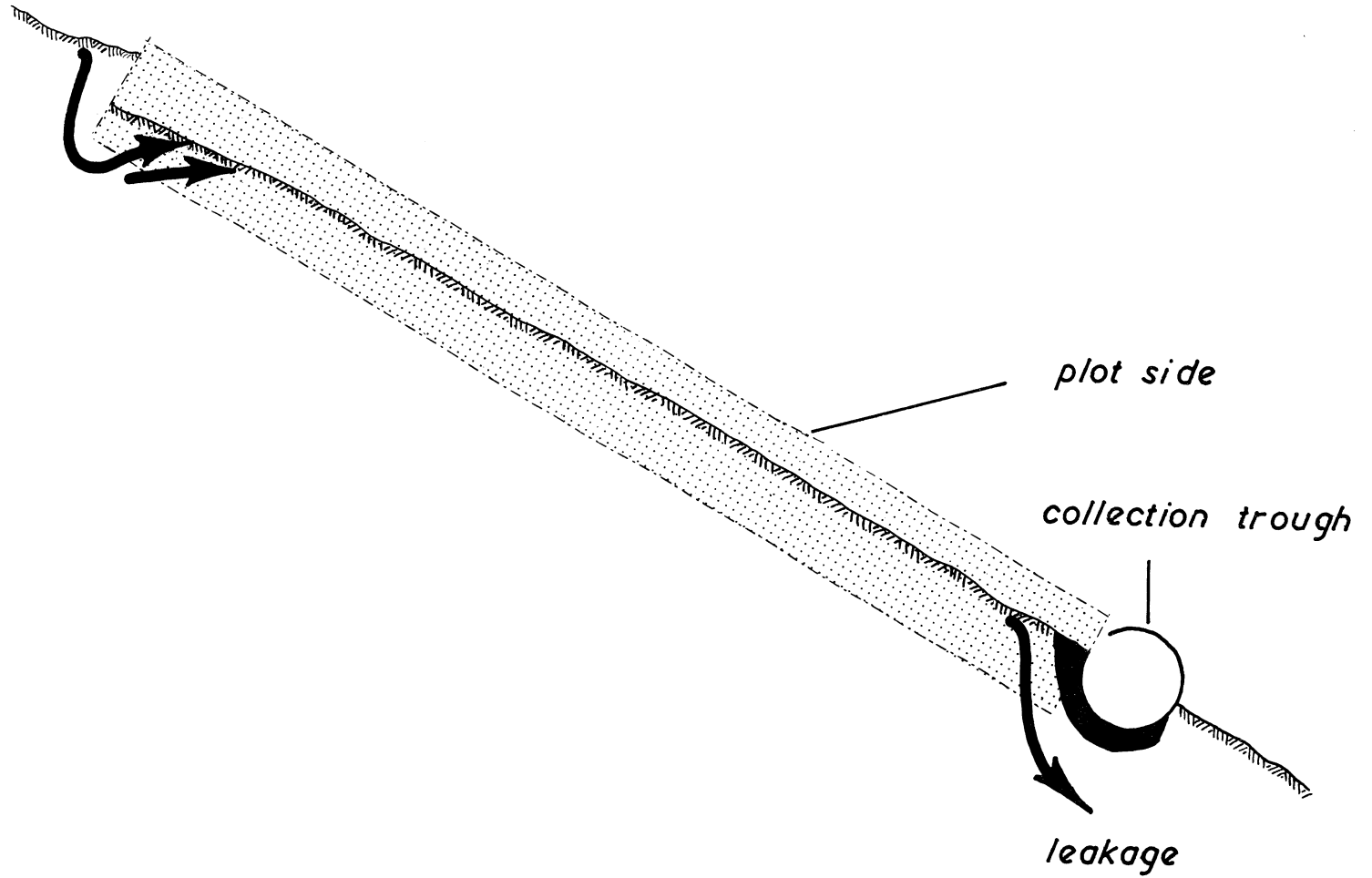

Fig. 3.

Longitudinal section of runoff plot showing leakage pattern.

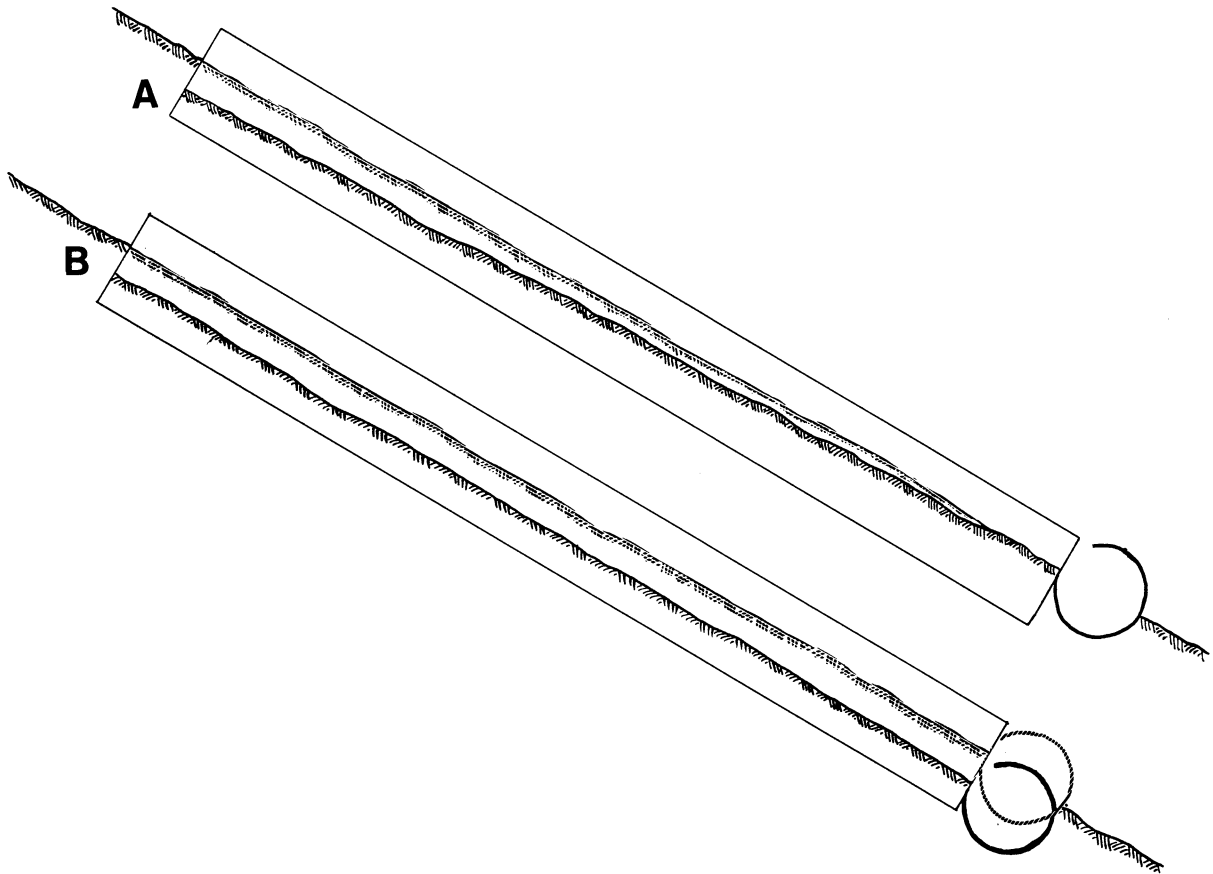

Fig. 4.

Longitudinal section of runoff plot showing

- A. Change of slope when collection trough is in a fixed position.
- B. Lowering of soil surface when collection trough can be adjusted.

3. Changes of slope

The erosion of material from a plot means a reduction in the soil surface level. If the collection trough cannot be lowered to match this lowering of soil surface the slope of the ground surface must become less steep. (See fig. 2.) This means that the slope of the plot will vary from one year to the next. If the plot slope is not the same as it was previously it will not be valid to compare the behaviour of that plot between several seasons.

4. Border interference with the microclimate

Plot equipment may introduce other sources of bias by upsetting the microclimate at the ground surface. Although it may be difficult to quantitatively assess these sources of bias the author has found that the plot equipment has so altered the microclimate that some results are of limited value.

Some of the most important effects are:

i. Direct capture of rain in the collection trough.

Despite shielding, wind driven rain can accumulate in the collection trough in greater or lesser amounts depending on the wind direction in relation to trough opening. In very small plots more water may be contributed from direct capture than from surface water runoff. Usually it is not possible to distinguish between the two.

ii. Direct capture of windblown soil in the collection trough.

In a similar manner, windborne silt, sand or clay-sized particles are caught in the collection trough. The author has found that at some sites aeolian material is no problem. However, at other sites a significant part of the eroded fine material may be blown into the trough.

iii. Plot sides disturb air flow.

Although the plot sides may only protrude above the ground four to six inches, this barrier can significantly alter the pattern of air flow across the soil surface. The

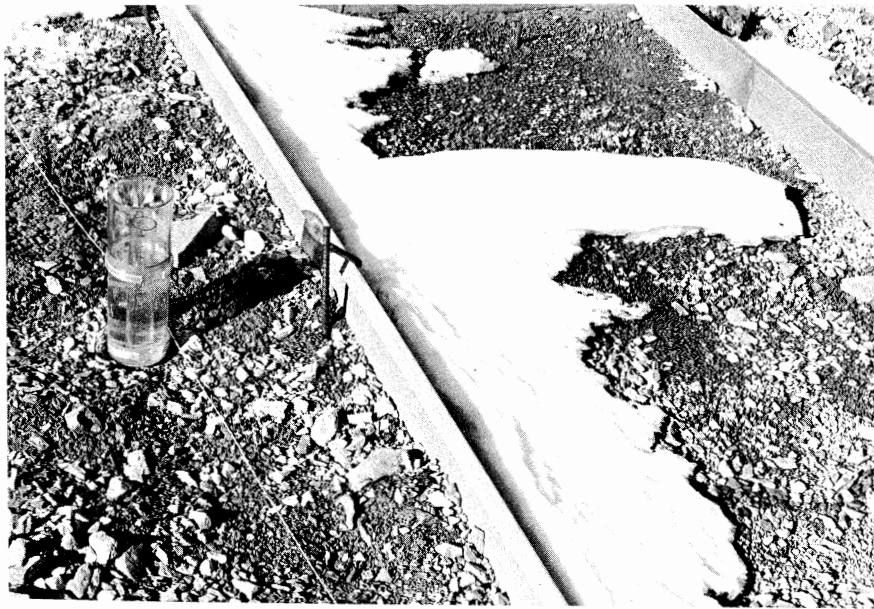

Fig. 5.

Accumulation of snow in the lee of plot side,
and an adjacent raingauge.

barrier effect of the plot side is most clearly shown when it snows. (See Plate 3.) The author has observed significant accumulations of snow in the lee of the plot sides. This effect of air flow over an impermeable barrier is difficult to quantify, but it can be safely assumed that the presence of the plot can, in some locations, result in a different total precipitation within the plot than would have occurred on the same site had the plot not been established.

b. Homogeneity

In Experimental studies a source of bias is found in the basic assumption of homogeneity. It is assumed that by siting plots in a similar environment (soil, aspect, slope, etc.) the influence of all variables but the treatment variable will be insignificant. The measured differences are therefore attributable to the treatment. This assumption ignores minor differences within the controlled variables which may or may not be significant. It is probable that this assumption will not always be valid and that some of the "controlled" variables may be involved in significant factor interactions.

The most satisfactory method of minimising this form of bias is in a good experimental design. In those studies which seek to evaluate a treatment a "homogeneous" site should be chosen, and the minor variations segregated into blocks. A battery of plots should be established within each block, and the treatments randomly assigned. This is the randomised block design, known and used in agriculture for many years.

In Observational studies the equivalent source of bias is found in a poor sampling procedure.

If the plot site is deliberately chosen as being "typical" of the characteristic under study, a maximum of personal bias is introduced. Similarly a haphazard sampling procedure will invariably produce a biased sample. Despite all efforts to be fair an investigator will over or under sample the physiognomic dominants. Experimental

trials of many types of sampling have shown how easily bias can be introduced when the sampler is permitted to exercise subjective judgement.

Systematic sampling has the advantages of simplicity and ensuring that the sample is well distributed throughout the population. However, it has the major disadvantage that there is no assurance that the estimate of error is valid. The only satisfactory method is one in which every individual of the population is given an equal opportunity of being chosen for the sample. This means that the sampling procedure must be based on random selection. If the sample has to be well distributed throughout the population, the population can be stratified and each strata randomly sampled.

3. STATISTICAL ANALYSIS

Runoff plot studies can be divided into those in which the investigator analyses data from his own plots, and those in which the investigator collects and reworks data from several studies. For convenience these are called "muddy boots" and "synthesis-analysis" studies respectively.

3.1 MUDDY BOOTS STUDIES

Of 50 studies reviewed by the author 46 did not replicate and randomise their treatments. However, almost all studies gave either a quantitative assessment of the results or compared the effectiveness of the treatments. Because these studies lacked a proper experimental design they were not able to carry out adequate data analysis. Their results are therefore unconvincing and should be used with care. They could be misleading.

While a number of authors replicated their treatments, they apparently have not statistically analysed the results. Many found wide variation between treatments and either meaned or totalled the results of each treatment. Comparisons between treatments were then made on the basis of these simple averages. (See for example Garde and

Van Doren (1949); Beale, Nutt and Peele (1955); Jones (1961); Logan (1960); Cameron (1952)). Comparisons such as these are unsatisfactory. Although it may be possible to rank treatments on the basis of a simple average there is no way of knowing whether or not the between treatment variance is significantly greater than the within treatment variance. Until this has been established, it is not possible to comment on the significance of the results.

Duley and Ackerman's 1934 study is worthy of note as it was the first, and still remains one of the few, to subject results to statistical analysis. From plots of different lengths, those authors found that runoff from short plots exceeded that from long plots on 96 out of 114 occasions. However, erosion from long plots was greater than that from short plots on 61 out of 114 occasions. Using Salmond's D.E. ratio,* they found values which suggested that the runoff results were not due to chance. It was therefore safe to conclude that short slopes would yield a larger percentage of runoff than long ones. The erosion results, however, were less consistent and the results did not appear to be statistically significant.

Similarly Dunford (1954) was able to evaluate the effects of three simulated grazing intensities on soil and water losses. Precipitation and soil and water losses were measured from six plots before applying the three treatments (two replicates). Erosion losses from grassland ranged from 111 lb to 163 lb per acre. These differences were statistically insignificant. After treatment soil losses per acre were 134 lb, 145 lb and 316 lb from no grazing, moderate grazing and heavy grazing respectively. Dunford found that significant increases in soil loss were obtained only from heavy grazing. He therefore concluded that moderate grazing was permissible on relatively gentle slopes covered in his experiment.

Similarly Mannering and Meyer (1963) reported results from their investigations into the effect of various rates of surface mulching on infiltration and erosion. They were able to show that the differences in soil loss between treatments were significant at the 1% level.

* Where D = standard deviation and E = probable error

The statistical analyses (which are necessary before the results can be discussed in a meaningful way) are not complex, and are covered in most statistical texts. It is important to note however that the major features of analysis are determined by the experimental design. No statistical procedure can compensate for poor design. Therefore it is essential, that before runoff plots are established, the experimenter must decide how he will handle his results.

Perhaps the one most useful statistical procedure is the Analysis of Variance. The object of this method of analysis is to establish whether or not the differences between treatments are significant or merely due to chance.

A null hypothesis is adopted, that the differences between treatments are chance events and not due to the treatments. The variance within replicates of the same treatment is then compared with the variance between treatments. As the ratio of variance within treatments to variance between treatments becomes greater, the null hypothesis is less likely to be valid. Statistical tables show the probability that the variance ratio (or F value) will exceed stated levels.

3.2 SYNTHESIS-ANALYSIS STUDIES

A second approach to data analysis is to collate data from several studies and search it for those variables which give the best explanation of variations in erosion and surface water runoff.

In recent years, data from many plot experiments in the United States have been collected at the Agriculture Research Service Runoff and Soil Loss Data Centre at Purdue. Up to 10,000 years of data have been accumulated and analysed for the variables which are primarily responsible for the differences in soil loss and runoff from cropland. Regression analyses have been used extensively, and several variables have been shown to have a close relationship with soil and water loss. For example Wischmeier (1959) searched 8,000 plot years of data to determine the storm characteristics which influenced soil

loss. Multiple regression analyses showed that the variable E.I.* was the characteristic which gave the best indication of a storm's ability to erode soil.

Studies such as these are very valuable in that they improve our understanding of the influence of the many variables which affect runoff and erosion. However, their conclusions must be accepted with some reservations. It has been emphasised that the data from runoff plots may be suspect. If the data are suspect, no statistical procedure can produce convincing results.

Even if the data are clean, the usefulness of analytical procedures is limited, in that no statistical procedure can ever uncover the basic mechanisms, or physical processes of the rainfall, runoff, soil loss process. Similarly, while correlation procedures are valuable in testing well grounded hypotheses, causality cannot be implied from relationships found between variables. It is quite possible to make wrong assumptions about the parameters under study and yet still find relationships between them. It is therefore a mis-application of these procedures to search randomly for the variables which give the best explanation of measured differences. This approach can lead to spurious correlations and nonsensical results.

This searching procedure may be justified on the grounds that it provides answers to pressing practical problems. The risks of nonsensical results are minimised when used by people who understand the physical processes involved. However, as a research approach it can be argued that this procedure runs contrary to the accepted rules; that of proposing a hypothesis, testing it, and then either accepting or rejecting it.

* E.I. is the product of a storm's total kinetic energy and its maximum 30 minute intensity

4. EXTRAPOLATION

4.1 FROM INDIVIDUAL STUDIES

Notwithstanding the inadequacies of experimental design and the lack of statistical analyses of results, most authors have assumed that their results have had an application beyond the plot. While most have been cautious about extrapolation, some have not. For example Lamy (1949) quoted the results from storms on one $\frac{1}{40}$ acre plot as:

<u>date</u>	<u>points of rain</u>	<u>soil/ac (lb)</u>	<u>% runoff</u>
8.12.47	259	7,879	43
13.12.47	123	5,819	56
21.12.47	91	8,470	62

Cox (1950) quoted the same figures and noted that they:

"... were obtained as a result of research into runoff and soil loss at Wagga Soil Conservation Research Station, which is situated in the Riverina district of New South Wales [Australia]. Results are therefore applicable to a large part of the southern wheat belt." (Italics mine).

Similarly Logan (1960) reported of his own work:

"... the results have been obtained from small plots, under specific land use treatments, and are on a single slope and soil type and consequently must be interpreted with these factors in mind. However, both the soils and slopes are typical of much of the Wellington district [New South Wales] and it is considered that the results are applicable over a fairly wide area."

The difficulties of extrapolating beyond the plot were well illustrated by Carreker (1949). He noted that in one storm the maximum rate of runoff from a 19.2 acre catchment was 2.3 inches per hour. However the maximum rate from fractional acre plots of similar slope and

cover for the same storm were in excess of four inches per hour.

Discrepancies of this magnitude show quite clearly that plot data cannot be simply extended to apply to larger areas. Before such data can be extended the bias due to boundary effects must be adequately explained.

To date no study has attempted to account for boundary effects in order that the plot data may be validly extrapolated. It is worth noting that boundary effects have been recognised for some time as the major limitation to the use of infiltration plot data. While infiltrometers may give index values of infiltration rates, these are of no use in determining initial and continuing losses from catchments as they do not include such phenomena as inter-flow, transmission losses and non-contributing areas.

However, even if these difficulties can be overcome in plot studies, the results can only give information about gross soil movement, and not net soil loss. Meck (1949) has shown clearly the distinction between these phenomena. He found that on 900 foot "plots" there was active soil movement in the upper and mid sections but there was no loss at the bottom. It seems probable therefore that even with good experimental design and data analysis, the difficulties and uncertainties of extrapolation may limit the usefulness of runoff plots as a research technique for the future, particularly for Observational studies.

4.2 EXTRAPOLATION THROUGH THE USE OF RATIONAL OR EMPIRICAL EQUATIONS

Many attempts have been made to relate plot data to field conditions through rational or empirical equations. Zingg (1940) analysed soil loss data from several studies for the influence of degree and length of slope. As an expression of the effect of slope factors on soil loss he proposed the rational equation

$$X = CS^{1.4}L^{1.6}$$

where X = total soil lost from a land slope of unit width

S = degree of land slope

L = horizontal length of land slope

C = a constant of variation which combines the effect of weather, soil crops or rotation and treatment.

Zingg did not assume that the equation represented absolute values for any specific soil or condition. It was merely the average of the available data.

Musgrave (1947) suggested that soil loss could be predicted from the equation

$$E = IRS^{1.35} L^{0.35} P_{30}^{1.75}$$

where E = soil loss in acre inches

I = inherent erodibility of soil in inches

R = a cover factor

S = degree of slope in percent

L = length of slope in feet

P₃₀ = maximum 30 minute rainfall amount for a two year frequency, in inches

Smith (1941) suggested that plot data could be applied to field conditions if it was modified by Woodruff's rational equation

$$A = CS^{7/5} L^{3/5}$$

where A - average soil loss in tons per acre per year and C, S and L represented the characteristics defined by Smith and Zingg. As the values of A, S and L are known for a given plot over a given time period, the value of C may be determined.

"If the plots are operated up and down hill and the equation is to be used in making field applications involving mechanical practices (such as contouring,

terracing, strip cropping) a factor must be introduced into the equation to provide for the effect of the practices. If the soil loss with a given practice is expressed as A_1 then $A_1 = AP \dots$ "

(Where P = the conservation practice.) Therefore

$$A = \frac{A_1}{P} = CS^{7/5}L^{7/3}$$

If the values of C, S, A and P are known then maximum slope length can be determined by solving

$$L = \frac{A_1}{PC} \quad 5/3 \quad 7/3$$

Using this equation Browning, Parish and Glass (1947) attempted to extend plot data to soils which had not been studied. By incorporating a number of estimates in the equation they predicted soil losses for several Iowa soils.

Smith and Whit (1948) used the equation

$$A = C.S.L.K.P.$$

where A = average annual soil loss in tons per acre per year

C = average annual related soil loss from plots in tons per acre per year

S.L.K.P. are multipliers to adjust the plot soil loss (C) for percent slope (S) length of slope (L) soil group (K) and conservation practice (P), when their field values are different from their plot values. The authors noted that if the equation was used in another climatic district a rainfall factor would have to be included. Values were provided for each factor on a Shelby soil so that probable field losses could be calculated from plot loss data. The authors also reported that the equation had been used to calculate erosion losses in north Missouri from storms in May and June of 1947. Calculated losses from cultivated land averaged 28 tons per acre. The results of a field survey indicated losses of 30 tons per acre.

Van Doren and Bartelli (1956) reported that the use of their equation made it possible to quickly and accurately estimate soil loss for almost any possible combination of conditions. Each factor known to influence erosion was given an erosion influence value which could be used in the equation

$$A = (T.S.L.P.K.I.E.R.M.)$$

- where A = annual estimated soil loss in tons per acre
- T = tons per acre of measured soil loss from soil type (considered unity) of given slope with known conservation practices and cropping pattern
- S = steepness of slope
- L = length of slope
- P = practice effectiveness (appropriate factor expressing effectiveness of the particular supporting practice or practices under consideration in solving for A above)
- K = soil erodibility
- I = intensity and frequency of 30 minute rainfall
- E = previous erosion
- R = rotation effectiveness
- M = management

In 1961 W.H. Wischmeier proposed the Universal Soil Loss Equation; (Olson and Wischmeier, 1963).

$$A = R.K.L.S.C.P.$$

- where A = soil loss in tons per acre
- R = rainfall erosion index
- K = soil erodibility factor
- L = length of slope factor
- S = percent slope factor

C = cropping - management factor

P = factor for special conservation practices

A and K have dimensions of tons per acre while all other factors are dimensionless.

The relation between, and the values of, the factors in this equation, have been reported by Smith and Wischmeier (1957); Wischmeier, Smith and Umland (1958); Wischmeier (1959, 1960, 1966); Olson and Wischmeier (1963). The application of the prediction equation to field conditions has been described by Springer, Breinig and Springer (1963) for Tennessee, Thoreson and Maddy (1963) for Iowa, Longley and Bondy (1963) for Kansas. These descriptions note that the equation has been adapted to a slide rule form to enable rapid computation of soil loss in the field.

These methods of predicting soil loss are essentially empirical and as such they are subject to the limitations of all empirical methods. Of them the Universal Soil Loss Equation is without doubt the most reliable and can be used with reasonable confidence in those areas for which it has been designed. However it must be remembered that despite its logical basis and the theoretical testing of some of its components it is still an empirical procedure. Because it cannot therefore be adapted to areas beyond those for which it was devised, its "Universality" is questionable.

It should also be remembered that this prediction equation was developed because a large quantity of data were available. In New Zealand and Australia where there is relatively little such information it is doubtful whether the development of a comparable prediction equation could be justified. It is the author's opinion that the research effort would be better placed in studies designed to understand the mechanisms of the erosion processes.

SUMMARY PART I

As with any experimental work, runoff plot research can only provide useful information if the experiments are soundly designed. Although runoff plots have been widely used for many years they have almost always been characterised by poor experimental design and inadequate analyses of data. Apparently most of the attention has been focused on the design of equipment but very little attention has been paid to experimental design.

In this respect the most serious deficiency has been the absence of replicated treatments. Of the few studies which did replicate their treatments most did not locate these in a random fashion. It has been emphasised that the twin requirements of replication and randomisation are essential if any experiment is to establish the differences between treatments, and the confidence which can be placed in the results.

Soil loss plot studies have been classified as either Experimental or Observational, depending on the object of study. It has been suggested that Experimental studies should be based on the randomised block design and that Observational studies should be based on a randomised sampling procedure.

Attention has also been drawn to the fact that few studies have used statistical methods to assess the significance of their treatments. This lack, together with the generally inadequate experimental design means that the results from most studies are unconvincing. It has been emphasised that the data analyses necessary for satisfactory conclusions to be drawn are not complex and are covered in most statistical texts. They are however largely determined by the type of experimental design used. The single most useful method of data analysis is the analysis of variance.

Attention has also been drawn to the fact that fractional acre runoff plots are a comparatively crude method of hydrological research. While they may provide results these will almost certainly be biased. Eight of the most

important sources of bias have been identified as due to the plot equipment itself, or the assumptions of homogeneity. Unless particular attention is paid to the problems of bias the data cannot be extrapolated beyond the plot with any degree of confidence.

The extrapolation of data beyond the plot has also been discussed. It has been noted that many authors have been over confident in the application of their results. Because Observational studies generally measure gross soil movement and not net soil loss it has been suggested that the difficulties associated with extrapolation may limit the usefulness of runoff plots as a research technique in the future.

PART II
REVIEW OF STUDIES

Although the author is somewhat critical of the use of fractional acre plot studies in the past, it may be of interest to note the sort of studies which have been made. Part II, is a brief review of some studies and the conclusions drawn by some workers. The author wishes to emphasise that most of these studies had an inadequate experimental design, and their data were inadequately assessed. Results should therefore be accepted only as a qualitative guide.

1. THE INFLUENCE OF PLANT COVER

Many authors have used plots to compare erosion and surface runoff losses under grass swards and other cultivated crops. For example Duley and Miller (quoted by Duley, 1952) used $\frac{1}{80}$ acre plots to measure the effects of different crops and tillage practices on runoff and erosion. Table I shows a summary of their results.

Plot	Treatment	Runoff %	Erosion tons/acre	Years to erode top 7"
1	Uncultivated - bare	48.9	34.6	29
2	Ploughed 4"	31.3	41.2	24
3	Ploughed 8"	28.4	35.7	28
4	Corn annually	27.4	17.7	56
5	Wheat annually	25.2	6.6	150
6	Rotation corn wheat clover	14.1	2.3	437
7	Sod	11.6	0.3	3547

Table I

The effect of different cropping systems and tillage methods on the annual loss of water by runoff and soil by erosion. (Average of six years' results. Missouri Research Bulletin 63) quoted by Duley, 1952.

Uhland (1935) noted that although the percentage of precipitation lost as runoff may be quite high under a grass sward, the amount of soil loss was usually low. J.R. Carreker in a submission to the Committee on Agricultural Hydrology (1948) supported this view when he stated that, while ground cover was important in reducing the amount of runoff, it was even more important in reducing the amount of soil loss. Many authors have emphasised this aspect of ground cover, among them, Dickson (1929); Horner, McCall and Bell (1944); Marston (1952); Kittredge (1954); Costin, Wimbush and Kerr (1960); Gilmore (1965).

Borst and Woodburn (1942) showed that where the surface soil was exposed to raindrop splash, soil particles became detached and were removed in runoff. However where the soil was protected by a mulch suspended just above the surface, the raindrop energy was dissipated before it struck the ground, and although there was little difference in runoff, there was a marked reduction in soil loss. From this the authors concluded that raindrop splash, not runoff, was responsible for soil loss.

Veihmeyer (1951) reported that when plant cover was destroyed by fire, maximum soil losses from the burned plots were 21 times that from unburned plots. However he also noted that this difference represented only 0.0004 of an inch per plot. Lowdermilk (1930, 1931) reported that the destruction of forest litter increased soil losses from 50 to 6,000 times. He described cultivation without adequate precautions as "suicidal agriculture".

2. THE INFLUENCE OF CROPPING AND CULTIVATION

Lowdermilk's concern for adequate precaution with cultivation has been shared by many authors who have investigated soil and water losses associated with cropping and cultivation. Moldenhauer and Wischmeier (1960) showed that contour cultivation, as opposed to up and down slope cultivation, reduced soil and water losses. Young, Mutchler and Wischmeier (1964) found that, regardless of

slope, soil loss from all plots farmed across slope, was 27% of the total for all plots farmed up and down slope. Even on a two percent slope, Van Doren and Bartelli (1956) found that contour farming reduced soil loss to about one half of that from up and down slope cultivation.

A minimum number of tillage operations has also been shown to reduce soil loss, (Meyer and Mannering, 1961) and if such operations left part of the crop residue on the surface of the soil, losses were substantially reduced. (Neal, 1939; Beale, Nutt and Peele, 1955).

All authors who investigated soil losses from cropping systems reported benefit from longer rotations, regardless of soil type of slope. For instance, Whitaker, Jamison and Thornton (1961) found that soil loss from corn grown in rotation was only 60% of that from continuous corn. In Australia, Lamy (1949), Cameron (1952), Logan (1960) and Jones (1961) reported increased soil losses with shorter rotations. North American workers have found similar results, and Carreker (1946) noted that the influence of the rotation became greater as slope increased.

Several authors reported that cereals should be grown in rotation with a legume and/or grass (Carreker, 1946; Horner, 1960; Adams, Henderson and Smith, 1959) as these acted as a cover crop and protected the soil during the winter. It was also found that even after the cover crops had been ploughed in, they continued to be beneficial. (Woodburn, 1945; Neal, 1939; Duley, 1939; Brill and Neal, 1950; Beale, Nutt and Peele, 1955.)

Jones (1961), and many other authors, reported that soil loss and runoff varied widely from year to year, and that this variation was often as great, or greater, than the variation between treatments. However seasonal losses within a year tended to follow a more regular pattern (Brill and Neal, 1950). Many authors could therefore identify the period of greatest hazard. Thus Brill and Neal (1950) found that in New Jersey, the greatest losses were likely to occur in the summer and early autumn. Horner, McCall and Bell (1944) found that in

Washington, winter was the critical period. Lamy (1949) found that in New South Wales (Australia) the greatest losses occurred from January to June, which was also the time when wheat fields were fallow and in a finely cultivated state prior to sowing. Consequently he advocated either a shorter fallow, or contour, and stubble mulch farming.

3. THE INFLUENCE OF SLOPE STEEPNESS AND LENGTH

Garde and Van Doren (1949) reported that while cropping was without doubt an important factor in soil loss, there were some situations in which slope factors dominated the erosion process.

The first studies on the effect of slope are attributed to F.O. Bartelli in 1927, (Duley and Ackerman, 1934) and these were followed by laboratory and field experiments by Duley and Hays in 1932. Neal (1937) used a constant length laboratory plot which could be adjusted for degree of slope. By applying simulated rainfall to a "fallowed" surface, he found that soil losses varied as the 0.7 power of the degree of slope.

In 1940, Zingg analysed plot data for the influence of slope on soil loss. As the plots had not always been designed for slope studies some adjustments to the data were necessary to enable him to make comparisons. The average of the adjusted data showed that doubling the degree of slope increased soil loss 2.8 times, and doubling the horizontal length of slope increased yield 3.03. Zingg then applied simulated rainfall to various degrees and lengths of slope. The averaged results shows that doubling the degree of slope increased soil loss 2.61 times, and doubling the horizontal length of slope increased loss by 3.03 times. From this he suggested that the influence of the slope factors could be expressed in the forms:

$$X = CS^m L^n$$

and

$$A = CS^m L^{n-1}$$

where X = total soil loss from land slope of unit width

L = horizontal length of land slope

S = degree of land slope

C = constant of variation

A = average soil loss per unit area from a land slope of unit width

m = the exponent for degree of land slope

n = the exponent for horizontal length of land slope

For field conditions the relation of slope length and degree to soil loss could be expressed in the rational equation

$$X = CS^{1.4}L^{1.6}$$

Borst and Woodburn (1940) using artificial rainfall on fallow plots reported a similar exponent for degree of slope of 1.3. Musgrave (1947) found exponents of 1.35 for degree of slope and 0.37 for length of slopes. Similar exponents were noted by Browning, Parish and Glass (1947). Van Doren and Bartelli (1956) found exponents of 1.45 and 1.53 for five and nine percent slopes respectively, with an average of 1.5. Using plot lengths of 36, 70, 140 and 210 feet the same authors found that the exponent of horizontal slope length varied from 0.4211 on five percent slopes, to 0.3499 on nine percent slopes. The average was 0.38.

Smith and Wischmeier (quoted by Wischmeier, Smith and Uhland, 1958) analysed data from plots on slopes between three percent and 22 percent. They suggested that the data was more accurately fitted by a parabolic curve than by the exponential type. They presented the equation

$$A = 0.43 + 0.30S + 0.04S^2$$

where A = soil loss in tons per acre

S = percent slope

Wischmeier, Smith and Uhland (1958) noted that:

"Evaluation of the effect of percent slope on soil loss was complicated by three major weaknesses in data: (a) the data are too limited, (b) the slope effect is frequently completely confounded with the effectiveness of contouring which is itself believed to be a function of slope, and (c) with few exceptions the range of slopes included in an experiment was too small to give a good indication of the type of curve that would best describe the relationship."

They also noted that the relation of slope factors to soil loss often varied more from year to year on the same plot than it varied between plots. In severe storms general trends were sometimes reversed. From an analysis of 15 sets of data from north central, and north eastern states the authors noted a "rather wide" variation in the slope-length exponents. However these differences were not significant at the 10 percent level and their weighted arithmetic mean was 0.46. They noted that a group meeting at Purdue in 1956 recommended a slope length exponent of 0.5 ± 0.1 and this value of 0.46 was within these limits.

Barnett and Rogers (1966) carried out a simulated rainfall study, and tested 34 independent variables for the influence on soil loss. "The best predictive factor for soil loss per E.l.* was (slope)^{1.7} which explained 75 percent of the variation per E.l." (In this as in all studies slope was measured in percent.)

However a study by Meck (1949) is at variance with the generally accepted findings. He investigated soil loss from row crops under irrigation. His "plots" were irrigation furrows rather than conventional runoff plots. From these he measured soil loss from lengths up to 900 feet. He found active erosion at the top end of the field, but no soil or water losses at the bottom. From this he concluded that in this case at least the conventional measure of soil loss in tons per acre from the bottom of the plot, was of no value in determining erosion losses or soil movement on the field. Garde and Van Doren (1949) considered that the shape of the slope may be of greater importance than its length.

* E.l. is the product of a rainstorm's total kinetic energy and its maximum 30 minute intensity

4. THE INFLUENCE OF RAINFALL FACTORS

Baver (1937) recognised intensity and amount as two of the important rainfall variables which affected soil loss. However the results from plot studies analysed for these two characteristics were very variable.

It has been established that high intensity storms tend to mask cultivation treatments (Moldenhauer and Wischmeier, 1960) and that a few such storms cause a high proportion of the total soil loss. (Brill and Neal, 1950). Lamb, Free and Wilson (1944) reported that over a $7\frac{2}{3}$ year study 13 percent of the total number of rains which produced runoff caused 57 percent of the total soil loss. Carreker (1954) found that soil loss between seasons varied from five to 51 tons per acre and that this was caused by the number of erosive storms,* rather than the total volume of runoff. These storms accounted for 75 to 90 percent of the total soil loss.

In an attempt to determine rainstorm characteristics which influenced soil loss Wischmeier (1959) analysed 8,000 plot years of data from 37 widely scattered projects. From multiple regression analyses the variable E.l.+ was found to be the characteristic which gave the best indication of a storm's ability to erode soil. When E.l. values for storms greater than 0.5 inches were summed for each year, they explained 72-85 percent of the yearly variation in soil losses for widely separated localities.

Rogers, Barnett and Cobb (1964) investigated the influence of simulated rainfall and slope length, and their interactions on soil loss. A regression of soil loss on the product of rainfall intensity and amount explained 81 percent of the variation in soil loss. However the product of rainfall intensity x rainfall amount x (slope)^{0.7} explained 92 percent of the variation. None of the measured chemical or physical soil characteristics were effective in explaining variation in either soil loss or runoff.

* An erosive storm was defined as one which removed more than 1,000 lb of soil per acre from continuous cotton.

+ See footnote p. 18

5. THE INFLUENCE OF SOIL CONSERVATION PRACTICES

One of the early problems facing the soil conservation movement in the United States, was that of evaluating the effectiveness of the proposed remedial measures.

Smith (1941) estimated that terracing in association with contour farming reduced soil loss to three percent of that from up and down hill operations. Carreker (1946) reported that soil loss from plots on a seven percent slope, was in the order of 28 to 82 tons per acre per year. However on an 11 percent slope of half the length, losses amounted to only 25 tons per acre per year. Consequently the author recommended terrace intervals of 70 feet on a seven percent slope, and 35 feet on an 11 percent slope.

Soil ripping, which also breaks surface length and interrupts overland flow, has been shown to be effective in some situations. Dortignac and Hickey (1963) found that ripping reduced soil losses by up to 85 percent and water losses by up to 96 percent.

Strip cropping has been shown to substantially reduce soil losses. Losses from plots which were strip cropped were shown to be about one half of those from contoured plots (Van Doren and Bartelli, 1956, quoting work of Borst et al 1945, Smith et al 1945, Hays et al 1949).

Mannering and Meyer (1961) investigated the management of crop residues as a conservation practice. They showed that shredding cornstalks in the autumn, and leaving the residue on the surface, reduced winter soil losses by 50 percent. Both Duley (1939) and Horner et al (1944) recommended that after harvesting, crop residues be left on the soil surface to reduce soil losses in the winter and early spring. Taylor, Hays, Bay and Dixon (1964) noted that continuous corn yielded three bushels per acre more than corn grown in a three year rotation. To avoid the soil losses associated with continuous cropping the authors investigated mulching techniques and found that a mulch of corn stover and barnyard manure gave excellent control of soil and water losses.

A number of studies have accepted mulching as an effective technique but have been concerned with types and rates of mulch application. For example Swanson and Dedrick (1965) tested 19 mulch treatments for their ability to protect a soil surface against water erosion. They concluded that on a pound for pound basis, prairie hay and wheat straw were comparable and were more effective than woodchips. The most effective treatment was half a ton per acre of prairie hay anchored with $\frac{1}{16}$ pint of asphalt emulsion per square yard. Similar studies have been reported by Swanson, Dedrick, Weakly and Haise (1965).

6. THE INFLUENCE OF SOIL FACTORS

Comparatively few plot studies have investigated the influence of soils, and soil factors, on erosion and runoff. Peel (1937) studied the physical characteristics of some soils, and concluded that their relative erodibility was indicated by such characteristics as, percolation rate, suspension percent, and dispersion ratio.

Van Doren and Bartelli (1956) deduced an erodibility rating for six Illinois soils. Their deduction involved adjusting soil loss data from different studies for uniformity of slope length cropping practice, rainfall intensity, and other factors. Similarly Barnett, Rogers, Holladay and Dooley (1965) found the relative erodibility of 13 soils in South Carolina and Georgia.

7. THE EROSION PROCESS

Lowdermilk and Sundling (1950) used lysimeters to study the formation and significance of an erosion pavement. They found that the erosion rate decreased throughout a simulated rainstorm as the finest particles were removed in surface flow. Their removal led to the larger particles domin-

ating the soil surface until ultimately an erosion pavement was formed. An analysis of the eroded material showed that it contained a greater proportion of fine material than did the original soil. Similar results were found by Swanson, Dedrick and Weakly (1965).

SUMMARY AND CONCLUSIONS PART II

Despite the limitations of poor experimental methodology discussed in Part I, Part II shows that plot studies have been useful in improving our understanding of erosion and its prevention. For example even if the study quoted by Duley (1952) had a number of deficiencies in its experimental design, these cannot discredit the very real differences found between extreme treatments. What the inadequacies in design do mean however, is that these differences can only be accepted as a qualitative guide. Because of this, studies like that quoted by Duley are of little value in assessing the differences between moderate treatments.

Researchers are usually more concerned with detecting the differences between moderate treatments than they are with extremes. If runoff plots are to be useful in future for quantifying the differences between moderate treatments they must be used in much stricter experimental designs than they have in the past.

It can be claimed that in following the strict requirements of good experimental design a study would become uneconomic, or impracticable or both. Even if the data are qualitative they may give a useful indication of the importance of the factors in the rainfall runoff process.

However it is the author's opinion that qualitative studies cannot be the object of current or future research. The good design needed for quantitative studies may be costly but qualitative studies and inadequate design are inefficient and in the long run, more expensive.

Furthermore, future studies must pay more attention to the problems of bias. This is most important where results are to be extrapolated beyond the plot, or where future behaviour is to be predicted. Unless the results of a study can, with confidence, be extrapolated or used to predict future behaviour, the value of the study is open to question.

BIBLIOGRAPHY

- 1 Adams, J.E.; Henderson, R.C.; Smith, R.M. 1959: Interpretations of run-off and erosion from field-scale plots on Texas blackland soil. Soil Sci. 87: 232-238.
- 2 Amerman, C.R.; McGuinness, J.L. 1966: Plot and small watershed runoff and its relation to larger areas. Paper prepared for the 1966 winter meeting of the American Society of Agricultural Engineers. 8 pp. cyclostyled.
- 3 Barnett, A.P.; Rogers, J.S.; Holladay, J.H.; Dooley, A.E. 1965: Soil erodibility factors for selected soils in Georgia and South Carolina. Trans. Am. Soc. Agric. Engr. 8: 393-395.
- 4 Barnett, A.P.; Rogers, J.S. 1966: Soil physical properties related to run-off and erosion from artificial rainfall. Trans. Am. Soc. Agric. Engr. 9: 123-125 and 128.
- 5 Baver, L.D. 1937: Rainfall characteristics of Missouri in relation to run-off and erosion. Soil Sci. Soc. Am. Proc. 2: 533-536.
- 6 Beale, O.W.; Nutt, G.B.; Peele, T.C. 1955: The effects of mulch tillage on run-off erosion soil properties and crop yields. Soil Sci. Am. Proc. 19: 244-247.
- 7 Borst, H.L.; Woodburn, R. 1940: Rain-simulator studies of the effect of slope on erosion and run-off. (U.S. Dep. Agric. Soil Conserv. Serv. TP 36.)
- 8 Borst, H.L.; Woodburn, R. 1942: The effect of mulching and methods of cultivation on run-off and erosion from Muskingum silt loam. Agric. Engng, St Joseph, Mich. 23: 19-22.
- 9 Boughton, W.C. 1967: Plots for evaluating the catchment characteristics affecting soil loss. 1 - Design of experiments. N.Z. Jl Hydrol. 6: 113-119.

- 10 Boughton, W.C. 1968: Evaluation of changes in the land use regime. Water Resources Symposium. 40th ANZAAS Congress in Lincoln Papers in Water Resources 1: 71-99. Publ. by Lincoln College, N.Z.
- 11 Brandt, A.E. 1941: The design of plot experiments for measurement of run-off and erosion. Agric. Engng, St Joseph, Mich. 22: 429-432.
- 12 Brill, G.D.; Neal, O.R. 1950: Seasonal occurrence of run-off and erosion from a sandy soil in vegetable production. Agron. J. 42: 192-195.
- 13 Browning, G.M.; Parish, C.L.; Glass, J. 1947: A method for determining the use and limitations of rotation and conservation practices in the control of soil erosion in Iowa. J. Am. Soc. Agron. 39: 65-73.
- 14 Cameron, D.G. 1952: Studies in soil conservation at Cowra Research Station 1941-45. J. Soil Conserv. Serv. N.S.W. 8: 158-168.
- 15 Carreker, J.R. 1946: Proper cropping practices strengthen terraces on sloping ground. Agric. Engng, St Joseph, Mich. 27: 311-312 and 315.
- 16 Carreker, J.R. 1954: The effects of rainfall, land slope and cropping practices on run-off and soil losses. J. Soil Wat. Conserv. 9: 115-119.
- 17 Carreker, J.R.; Barnett, A.P. 1948: Submission to Committee on Agricultural Hydrology (Am. Soc. Agric. Engr.) Agric. Engng, St Joseph, Mich. 29: 114-116.
- 18 Costin, A.B.; Wimbush, D.J.; Kerr, D. 1960: Studies in catchment hydrology in the Australian Alps. II - Surface run-off and soil loss. (C.S.I.R.O. Div. Pl. Ind. Tech. Pap. No. 14.)
- 19 Cox, R.K. 1950: The land use factor in wheat-land erosion control. J. Soil Conserv. Serv. N.S.W. 6: 159-170.
- 20 Davis, W.E. 1937: A new method for measurement of erosion from experimental plots. Soil Sci. Soc. Am. Proc. 2: 579-583.

- 21 Dickson, R.E. 1929: The results and significance of the Spur (Texas) run-off and erosion experiments. J. Am. Soc. Agron. 21: 415-422.
- 22 Dortignac, E.J.; Hickey, W.C. 1963: Surface run-off and erosion as affected by soil ripping. Proc. Fed. Inter-agency Sediment Conf. 1963. U.S. Dep. Agric. Misc. Publ. 970: 156-165.
- 23 Duley, F.L. 1939: Surface factors affecting the rate of intake of water by soils. Soil Sci. Soc. Am. Proc. 4: 60-64.
- 24 Duley, F.L. 1952: Relationship between surface cover and water penetration, run-off, and soil losses. Proc. Int. Grassld Cong. 6: 942-946.
- 25 Duley, F.L.; Ackerman, F.G. 1934: Run-off and erosion from plots of different lengths. Agric. Res. Wash. 48: 505-510.
- 26 Duley, F.L.; Hays, O.E. 1932: The effect of the degree of slope on run-off and soil erosion. Agric. Res. Wash. 45: 349-360.
- 27 Dunford, E.G. 1954: Surface run-off and erosion from pine grasslands of the Colorado Front Range. J. For. 52: 923-927.
- 28 Feagan, W.T.; Redmond, J. 1955: Planning of hydrology experiments for forested catchments in Australia. Aust. N.Z. Ass. Adv. Sci. Sec. K. Melbourne.
- 29 Food and Agriculture Organisation 1965: "Soil erosion by water, Some measures for its control on cultivated lands". F.A.O. Agricultural Development Paper, No. 81, 284 pp.
- 30 Garcia, G.; Hickey, W.C.; Dortignac, E.J. 1963: An inexpensive run-off plot. U.S. For. Serv. Res. Note R.M. 12.
- 31 Garde, L.E.; Van Doren, C.A. 1949: Soil losses as affected by cover, rainfall and slope. Soil Sci. Soc. Am. Proc. 14: 374-378.

- 32 Gilmore, D.A. 1965: Hydrological investigations of soil and vegetation types in the lower Cotter catchment. (M.Ag.Sci. thesis. Aust. Nat. Univ. Canberra.)
- 33 Hayward, J.A. 1967: Plots for evaluating the catchment catchment characteristics affecting soil loss. 2 - Review of plot studies. N.Z. Jl Hydrol. 6(2):120-137.
- 34 Horner, G.M. 1960: Effect of cropping systems on run-off, erosion and wheat yields. Agron. J. 52: 342-344.
- 35 Horner, G.M.; McCall, A.G.; Bell, F.G. 1944: Investigations of erosion control and reclamation of eroded land at the Palouse Conservation Experimental Station, Pullman, Wash. 1931-42. (U.S. Dep. Agric. Tech. Bull. 860.)
- 36 Joint Committee of American Society of Range Management and the Agricultural Board, 1962: "Basic problems and techniques in range research". National Academy of Sciences - National Research Council, publ. No. 890: 169-189.
- 37 Jones, H.R. 1961: Run-off and soil loss studies at Wagga Research Station. J. Soil Conserv. Serv. N.S.W. 17: 156-169.
- 38 Kennedy, A.L. 1941: Equipment for run-off measurement. Agric. Engng, St Joseph, Mich. 22: 218 and 220.
- 39 Kittredge, J. 1954: Influences of pine and grass on surface run-off and erosion. J. Soil Wat. Conserv. 9: 179-185 and 193.
- 40 Lamb, J.; Free, G.R.; Wilson, H.H. 1944: The seasonal occurrence of soil erosion in New York as related to rainfall intensities. J. Am. Soc. Agron. 36: 37-45.
- 41 Lamy, D.L. 1949: Some effects of summer storms at Wagga Soil Conservation Research Station 1947-48. J. Soil Conserv. Serv. N.S.W. 5: 39-43.

- 42 Logan, J.M. 1960: Run-off and soil-loss studies at Wellington Research Station. Part I - Run-off. J. Soil Conserv. Serv. N.S.W. 16: 95-111.
- 43 Logan, J.M. 1960: Run-off and soil-loss studies at Wellington Research Station. Part II - Soil loss. J. Soil Conserv. Serv. N.S.W. 16: 214-227.
- 44 Longley, A.J.; Bondy, E.J. 1963: Reducing soil loss in Kansas. J. Soil Wat. Conserv. 18: 160-161.
- 45 Lowdermilk, W.C. 1931: Studies of the role of forest vegetation in surficial run-off and soil erosion. Agric. Engng, St Joseph, Mich. 12: 107-112.
- 46 Lowdermilk, W.C.; Sundling, H.L. 1950: Erosion pavement formation and significance. Trans. Am. Geophys. Un. 31: 96-100.
- 47 Madhavan, K. 1967: Calibration and development tests on a Coshocton type run-off sample. J. Soil Water Cons. in India 15: 93-102.
- 48 Mannering, J.V.; Meyer, L.D. 1961: The effects of different methods of corn-stalk residue management on run-off and erosion as evaluated by simulated rainfall. Soil Sci. Soc. Am. Proc. 25: 506-510.
- 49 Mannering, J.V.; Meyer, L.D. 1963: The effects of various rates of surface mulch on infiltration and erosion. Soil Sci. Soc. Am. Proc. 27: 84-86.
- 50 Marston, R.B. 1952: Ground-cover requirements for summer storm run-off control on Aspen sites in northern Utah. J. For. 50: 303-307.
- 51 Meck, S.J. 1949: Effect on slope and length of run on erosion under irrigation. Agric. Engng, St Joseph, Mich. 30: 379-383 and 389.
- 52 Meyer, L.D. Mannering, J.V. 1961: Minimum tillage for corn: its effects on infiltration and erosion. Agric. Engng, St Joseph, Mich. 42: 72-75 and 86-87.

- 53 Mirchandani, P.M.; Guha, D.P.; Vasudevaiah, R.D. 1958: Run-off soil loss studies at Deochanda Experiment Station: 1 - Effect of crop management practices. J. Soil and Water Cons. in India 6: 125-132.
- 54 Moldenhauer, W.C.; Wischmeier, W.H. 1960: Soil and water losses and infiltration rates on Ida silt loam as influenced by cropping systems, tillage practices and rainfall characteristics. Soil Sci. Soc. Am. Proc. 24: 409-413.
- 55 Musgrave, G.W. 1947: The quantitative evaluation of factors in water erosion - a first approximation. J. Soil Wat. Conserv. 2: 133-138.
- 56 Mutchler, C.K. 1963: Run-off plot design and installation for soil erosion studies. 27 pp. (U.S. Agric. Res. Serv. ARS - 41-79.
- 57 Neale, O.R. 1937: The effect of the degree of slope and rainfall characteristics on run-off and soil erosion. Soil Sci. Soc. Am. Proc. 2: 525-532.
- 58 Neale, O.R. 1939: Some concurrent and residual effects of organic matter additions on surface run-off. Soil Sci. Soc. Am. Proc. 4: 420-425.
- 59 Olson, T.C.; Wischmeier, W.H. 1963: Soil erodibility evaluations for soils on the run-off and erosion stations. Soil Sci. Soc. Am. Proc. 27: 590-592.
- 60 Peel, T.C. 1937: The relation of certain physical characteristics to the erodibility of soils. Soil Sci. Soc. Am. Proc. 2: 97-100.
- 61 Rogers, J.S.; Barnett, A.P.; Cobb, C. 1964: An evaluation of factors affecting run-off and soil loss from simulated rainfall. Trans. Am. Soc. Agric. Engr. 7: 457-459.
- 62 Singh, G.; Dayal, R.; Bhola, S.N. 1967: Soil and water loss (run-off) studies under different vegetative covers on 0.5 and 1.0% slope at Kota. J. Soil Water Cons. in India 15: 17-23.

- 63 Smith, D.D. 1941: Interpretation of soil-conservation data for field use. Agric. Engng, St Joseph, Mich. 22: 173-175.
- 64 Smith, D.D.; Whit, D.M. 1948: Evaluating soil losses from field areas. Agric. Engng, St Joseph, Mich. 29: 394-396 and 398.
- 65 Smith, D.D.; Wischmeier, W.H. 1957: Factors affecting sheet and rill erosion. Trans. Am. Geophys. Un. 38: 889-896.
- 66 Smith, D.D.; Wischmeier, W.H. 1960: Current concepts and developments in rainfall erosion research in the United States. Trans 5th Int Congr. Agric. Eng. (Brussels): 458-469.
- 67 Soons, J.M. 1966: Some observations of micro-climate and erosion processes in Cass Basin in the Southern Alps. (Paper delivered N.Z. Hydrol. Soc. Wellington, 1966.) Cyclostyled.
- 68 Springer, D.K.; Breinig, C.B.; Springer, M.E. 1963: Predicting soil losses in Tennessee. J. Soil Wat. Conserv. 18: 157-158.
- 69 Swanson, N.P.; Dedrick, A.R. 1965: Protecting soil surfaces against water erosion with organic mulches. (Paper delivered Am. Soc. Agron., Ohio, 1965.) Cyclostyled.
- 70 Swanson, N.P.; Dedrick, A.R.; Weakly, H.E. 1965: Soil particles and aggregates transported in run-off from simulated rainfall. Trans Am. Soc. Agric. Engr. 8: 437 and 440.
- 71 Swanson, N.P.; Dedrick, A.R.; Weakly, H.E.; Haise, H.R. 1965: Evaluation of mulches for water erosion control. Trans. Am. Soc. Agric. Engr. 8: 438-440.
- 72 Taylor, R.E.; Hays, O.E.; Bay, C.E.; Dixon, R.M. 1964: Corn stover mulch for control of run-off and erosion on land planted corn after corn. Soil Sci. Soc. Am. Proc. 28: 123-125.

- 73 Thoreson, A.S.; Maddy, J.K. 1963: Using the soil loss equation in Iowa. J. Soil Wat. Conserv. 18: 159-160.
- 74 Uhland, R.E. 1935: The effect of plant cover on soil and water losses. Symposia commemorating six decades of the modern era in biological science (Iowa State College) 1: 115-122.
- 75 Van Doren, C.A.; Stauffer, R.S.; Kidder, E.H. 1950: Effect of contour farming on soil loss and run-off. Soil Sci. Soc. Am. Proc. 15: 413-417.
- 76 Van Doren, C.A.; Bartelli, L.J. 1956: A method of forecasting soil loss. Agric. Engng, St Joseph, Mich. 37: 335-341.
- 77 Veihmeyer, F.J. 1951: Hydrology of range lands as affected by presence or absence of brush vegetation. Assoc. Int. Hydrol. Scient., Brussels, 1951: 226-234.
- 78 Whitaker, F.D.; Jamison, V.C.; Thornton, V.F. 1961: Run-off and erosion losses from Mexico silt loam in relation to fertilization and other management practices. Soil Sci. Soc. Am. Proc. 25: 401-403.
- 79 Wiltshire, C.R. 1947: Run-off plots and standard run-off and soil loss measuring equipment used by the New South Wales Soil Conservation Service. J. Soil Conserv. Serv. N.S.W. 3: 171-178.
- 80 Wischmeier, W.H. 1959: A rainfall erosion index for a universal soil-loss equation. Soil Sci. Soc. Am. Proc. 23: 246-249.
- 81 Wischmeier, W.H. 1960: Cropping/management factor evaluations for a universal soil-loss equation. Soil Sci. Soc. Am. Proc. 24: 322-326.
- 82 Wischmeier, W.H. 1966: Relation of field-plot run-off to management and physical factors. Soil Sci. Soc. Am Proc. 30: 272-277.

- 83 Wischmeier, W.H. 1967: Personal communication.
- 84 Wischmeier, W.H.; Smith, D.D. 1965: Rainfall erosion losses from cropland east of the Rocky Mountains. U.S.D.A. Agric. Handbook 282, 47 pp.
- 85 Wischmeier, W.H.; Smith, D.D.; Uhland, R.E. 1958: Evaluation of factors in the soil-loss equation. Agric. Engng, St Joseph, Mich. 39: 458-462 and 474.
- 86 Woodburn, R. 1945: A comparison of erosion losses after turning under legumes and non-legumes. Agric. Engng, St Joseph, Mich 26: 247-248.
- 87 Young, R.A.; Mutchler, C.K.; Wischmeier, W.H. 1964: Influence of row direction and type of vegetal cover on the slope/soil-loss relationship. Trans. Am. Soc. Agric. Engr. 7: 316-317 and 320.
- 88 Zingg, A.W. 1940: Degree and effect of land slope as it affects soil loss in run-off. Agric. Engng, St Joseph, Mich. 21: 59-64.

LINCOLN PAPERS IN WATER RESOURCES

- No. 1: Water Resources Symposium, 40th ANZAAS
Congress: Part 1.
- No. 2: Water Resources Symposium, 40th ANZAAS
Congress: Part 2.
- No. 3: Hydrologic Characteristics of Catchments -
Walter C. Boughton
Lag Time for Natural Catchments - A.J. Askew
- No. 4: Financing Catchment Schemes in New Zealand
- No. 5: The Measurement of Soil Loss from Fractional
Acre Plots

EDITORIAL COMMITTEE

Professor J.R. Burton, Director, N.Z. Agricultural
Engineering Institute and Head, Department of
Agricultural Engineering.

Mr W.C. Boughton, Senior Lecturer, Department of
Agricultural Engineering.

Mr G.R. Gilbert, Information Officer, N.Z. Agric-
ultural Engineering Institute.

